

FRAMEBUILDING NEWS

THE ONLY PUBLICATION SERVING THE POST-FRAME INDUSTRY FOR OVER 35 YEARS

WWW.FRAMEBUILDINGNEWS.COM



GREAT HABITS FOR THE NEW YEAR

WINDOWS FOR POST-FRAME BUILDINGS

RESKINNING A POST-FRAME BUILDING

FRAME BUILDING EXPO 2026
WHAT YOU'LL FIND IN OKLAHOMA CITY

SEE US AT THE FRAME BUILDING EXPO



BOOTH #218



BOOTH #327



BOOTH #735



BOOTH #442



BOOTH #838



BOOTH #621

DYNAMIC FASTENER

Everything for the Metal Builder & Roofer®

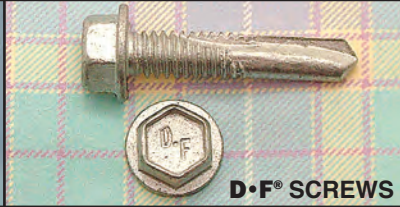

You supply the crew.
We'll supply the rest.®



CALL 800-821-5448 or Order Online @ DYNAMICFASTENER.COM
Call for your Free Full Color 140 Pg. Hand Guide. Better yet, call us for your next tool or fastener requirement. Discover for yourself why your peers enjoy doing business with our company!

PUBLISHER'S NOTE //

BY GARY REICHERT

The Power of Collaboration

Welcome to the issue of Frame Building News featuring the NFBA Conference & Expo.

A lot has been going on behind the scenes. Shield Wall Media is happy to announce we are embarking on a collaborative relationship with the National Frame Building Association. I firmly believe working together, toward common objectives, will help grow and improve the parts of post-frame construction we touch.

Collaboration is usually the answer.

Speaking of collaboration, help us promote Max Builds a Pole Barn. This is a children's book where a big fluffy dog builds a post-frame building to store a

boat. This is a great way to show your kids or grand kids what you do and introduce them to the trades. We are GIVING these books away to start children thinking about construction so they see it as a viable career path when they are older.

If you have schools, churches, libraries or organizations that would like more than one book, come see me at the Expo. We want to get copies of *Max Builds a Pole Barn* and *Max Builds a Metal Roof* into kids' hands. Hopefully this will bring a few more people into the trades.

We at Shield Wall Media would like to wish everyone a happy, healthy and prosperous 2026.

Now build something.

Gary Reichert, Publisher

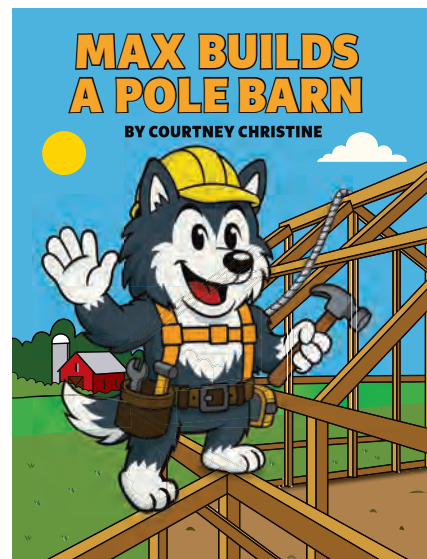

EDITOR'S NOTE //

BY KAREN KNAPSTEIN

See You In Oklahoma City

Welcome to the Frame Building Expo edition of Frame Building News! It won't be long now and we'll be meeting face to face in Oklahoma City ... I'm really looking forward to it as the NFBA always puts on a great event.

In this edition, you'll get a glimpse of what you'll find February 25-27 at the Oklahoma City Convention Center. At this event, builders gain face-to-face access to the people who know post-frame construction best. Engineers and designers

who specialize in post-frame are on hand to answer questions and discuss real-world challenges, while experienced builders openly share what works in the field — and what doesn't.

You'll also have opportunities to talk directly with technical experts who can help clarify gray areas before they become costly problems for you. That level of access is difficult to find anywhere but a trade show and proves invaluable when navigating complex designs, evolving codes, or unique jobsite conditions.

In addition, the Expo floor is curated

specifically for the post-frame industry, featuring materials, components, and equipment designed for post-frame construction — not generic building products. With fewer irrelevant vendors, conversations are more focused and productive. After all, hands-on demonstrations and direct discussions with manufacturers make it easier to identify solutions that improve building quality, increase efficiency, and boost your profitability.

Karen Knapstein, Editor
karen@shieldwallmedia.com
715-952-1633 (phone & fax)



CONTENTS

6 Product Feature

Windows in Post-Frame Buildings

12 NFBA, WFBA News

Frame Building Expo in Oklahoma City

16 Frame Building Expo

Don't Miss These Exhibitors

28 Building Wins

Great Habits To Start Off the New Year

30 Building Interest

Children's Book about Post Frame Coming Soon!

32 Post-Frame Refresh

Reskinning a Post-Frame Building

35 Families Welcome

At the 2026 Post-Frame Builder Show

36 Insulating Post-Frame

Advice and Insights from the Pole Barn Guru

40 Flashback: 2006

Concrete Piers and Post-Frame

51 Residential Style

A Closer Look at Post-Frame Garages

58 Elevate the Industry

How You Can Get a Post-Frame Building Project Published in Frame Building News



DEPARTMENTS

- 3 Editor's Note
- 47 Business Connections
- 54 New Products
- 55 Supplier News
- 59 Construction Survey Insights: Survey Data

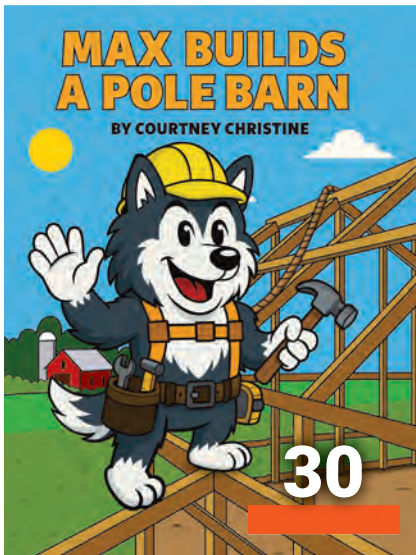

**GO TO PAGE 19 TO
SUBSCRIBE
TO MORE
FREE MAGAZINES**

**FIND US ONLINE AT:
framebuildingnews.com**

**CONTACT THE EDITOR AT:
karen@shieldwallmedia.com**

INDEX OF ADVERTISERS

Company	Page #
Acu-Form	16, 43, 50
AJ Manufacturing, Inc.	16, 43
AmeriLux International	CVR
ASC Machine Tools Inc.	49
ASCO USA, Inc.	49
ASTA America by Janus International	9
Atlas Building Products	16, 45
Aztec Washer Company	47
Balcan Innovations (rFOIL)	47
Bay Insulation	CVR, 16
BECK America, Inc.	48
Coil Spot • Wildcat • Speedlap LLC	50
Creekside Manufacturing LLC	47
Dalam Welding	49
Direct Metals, Inc.	50
Dripstop™	13, 16
Dynamic Fastener	IFC
E-Impact Marketing LLC	47
Everlast Roofing, Inc.	48
Flack Hill Machine	48
FootingPad	16
Formwright	49
Golden Rule Fasteners	23, 33, 50
Grabber Post Buildings, Inc.	18, 41
Grandura Distribution LLC	48
Gutterdome Manufacturing	48
Heartland Sales & Machine	48
Hixwood	18, 53
Indiana Warm Floors	47
LELAND Industries Inc.	18, 25
Marion Manufacturing	49
Maze Nails	11, 18
MWI Components	CVR, 18, BC
National Frame Building Association	15
Perma-Column LLC	17, 18, 49
Pine Hill Trailers	20, 29, 47
Planet Saver Industries / GreenPost	50
Plasti-Sleeve	48
Plyco Corporation	20, 27
Postsaver Europe Ltd.	47
Powerlift Hydraulic Doors	CVR, 20, 39
Red Dot Products, LLC	47
Rigidply Rafters	20, 37
Samco Machinery	50
Snap Z	CVR
Starwood Rafters	55
Steel Dynamics Inc.	7, 20
SteelGrip SAMM, Inc.	50
Storage Xpress Corp.	49
United Steel Supply	CVR, 49
Wick Buildings	53
Winding Road Roofing	48

**YOUR PRIVACY IS
IMPORTANT TO US**

Unrelated third parties often attempt to sell mailing lists for what they say are our publications. You can be assured that WE DO NOT, HAVE NOT, AND WILL NOT EVER SELL OUR SUBSCRIBER LISTS. We will also NOT sell the attendee or exhibitor lists from our shows. We do provide attendee lists to the exhibitors free of charge and as a courtesy for their support, but we NEVER provide this or any other information to independent vendors.

Gary Reichert,
Publisher, Shield Wall Media

FRAMEBUILDING NEWS

Managing Editor:
Karen Knapstein
karen@shieldwallmedia.com
715-952-1633 (phone & fax)

Editorial Staff:
Kathleen Riley, Linda Schmid

Circulation/Subscriptions:
Camin Potts
camin@shieldwallmedia.com
715-952-1682

Publisher/CEO:
Gary Reichert
gary@shieldwallmedia.com

Director of Events:
Missy Beyer
missy@shieldwallmedia.com
715-350-6658
Fax: 1-715-227-8680

Executive/Advertising Assistant:
Kathy Budsberg
kathy@shieldwallmedia.com

Advertising/Show Assistant:
Cari Ullom
cari@shieldwallmedia.com

Graphic Designers:
Tom Nelsen, Kevin Ulrich

FAX:
1-715-304-3604

Frame Building News (ISSN 1079-0870) (Volume 38, Number 1) is published five times per year (January, April, June, August and November) by Shield Wall Media LLC, 150 Depot St., Iola, WI 54945. Periodical postage paid at Iola, WI, and at additional mailing offices. Canadian Agreement Number: 40665675. POSTMASTER: Send address changes to Frame Building News, Camin Potts, PO BOX 255, Iola, WI 54945. Copyright 2026 Shield Wall Media LLC. Frame Building News and its logo are registered trademarks. Other names and logos referred to or displayed in editorial or advertising content may be trademarked or copyright. Frame Building News assumes no responsibility for unsolicited materials sent to it. Publisher and advertisers are not liable for typographical errors that may appear in prices or descriptions in advertisements. Technical articles appearing in Frame Building News are reviewed for technical content by an advisory committee consisting of a select group of post-frame industry and related academic personnel. Opinions and/or recommendations included in columns by guest authors are solely those of the authors. Frame Building News, committee members, staff, consultants and contributing authors disclaim any responsibility or liability for contents or opinions expressed in any article contained in Frame Building News. Publication by Frame Building News in no way implies endorsement of contents. Mailed free to post-frame builders and their suppliers throughout North America. Others may subscribe: U.S. \$21.98 for 1 yr, \$39.98 for 2 yrs, \$58.98 for throughout North America. Others may subscribe: U.S. \$21.98 for 1 yr, \$39.98 for 2 yrs, \$58.98 for 3 yrs; Canada, \$29.98 1 yr, \$56.98 2 yrs, \$84.98 3 yrs.

ON THE COVER:

An insulated post-frame building detail
courtesy of Troyer Post Buildings,
Tennessee.
Photo courtesy of Troyer Post Buildings.



Windows for Post-Frame Buildings

Details for Matching Form to Function

■ By Linda Schmid

Windows in post-frame construction serve a range of purposes—from providing simple light and ventilation in agricultural sheds to contributing to the comfort, efficiency, and curb appeal of barn-dominiums. Early post-frame windows were utilitarian: often aluminum 4×3 sliders or single-hung models that let in daylight without much thought to aesthetics or energy performance. Those still have their place in machine sheds and some barns, but modern post-frame buildings often aim to look and perform more like conventional homes. That evolution has pushed window technology and selection far beyond “whatever fits the opening.”

A window that performs well in a horse barn is not necessarily right for a living space, and vice versa. Builders today must weigh structural considerations, exposure, maintenance demands, and even animal behavior when specifying windows. In an equestrian arena, for example, the window should be high enough that a horse’s kick won’t make contact. Safety glass is a must. In hog barns or milking parlors, where chemicals, humidity, and corrosion are constant threats, wood frames are off the table and vinyl or aluminum become the go-to choices.

The key is understanding the environment and function of each space—whether the window’s main role is light, ventilation, or energy control—

and matching materials and details accordingly.

Material Choices

For post-frame builders, the most common window frames are vinyl and aluminum. Vinyl has become the standard choice for its combination of efficiency, durability, and low maintenance. It resists moisture and rot, doesn’t require painting, and provides better thermal resistance properties even compared to an aluminum frame with a thermal break. For residential-style post-frame buildings, vinyl may deliver the best balance of performance and cost.

Aluminum still has its uses, particularly in large openings or commercial-grade applications where structural strength matters more than energy performance. It’s strong, rigid, and available in commercial-grade extrusions that give a clean, professional look. The drawback is conductivity—without a thermal break, aluminum transfers heat and cold readily,



Harmony Vinyl Double Casement with an eyebrow transom, grids in the airspace and J channel. PHOTO COURTESY OF AJ MANUFACTURING

leading to condensation and higher energy loss. Quality models include a built-in thermal break, but they remain less efficient than vinyl or composite alternatives.

Fiberglass and composite window frames, while less common, are gaining interest. They expand and contract at a similar rate to glass, which can minimize stress and seam failure over time. Fiberglass can be painted for color flexibility, but it can scratch, and paint degradation can follow. Wood or wood-clad windows still appeal to some homeowners for aesthetic reasons, but they demand more upkeep and are rarely used in working post-frame environments.

For agricultural or animal structures, vinyl or aluminum thermal



Plyco Victory Vinyl Single Hung Windows. PHOTO COURTESY OF PLYCO.



TruSteel HD[®]
SDI  You Can See The Difference.

High-resolution images of real wood.
Digitally printed on steel.
Over 30 unique patterns.
Made in the USA.



Visit **Tru-SteelHD.com** or scan
QR code for more information.

Actual product color may vary from images shown due to lighting conditions, time of day, and atmospheric factors. For color accuracy, please request a physical sample.

© 2025 Steel Dynamics, Inc.

RESOURCES

A.J. Manufacturing, Inc. •
www.ajdoor.com

J&E Grill Manufacturing •
www.horsebarnsupplies.com/

Plyco Corp. • www.plyco.com

Shed, Windows & More •
<https://shedwindowsandmore.com/>

break windows work well. In barns, vinyl resists moisture and cleaning chemicals, while aluminum offers rigidity and durability. Often these windows offer a range of colors to match siding. Some manufacturers offer up to forty color options at the same price as white, simplifying design consistency across the façade.

Energy and Performance

Energy efficiency may not matter much in a machine shed, but it's essential in any conditioned post-frame building. Builders should look for NFRC-certified products that list U-values, Solar Heat Gain Coefficients (SHGC), and air



Plyco Victory Vinyl Single Hung Window.
PHOTO COURTESY OF PLYCO.

infiltration ratings. In most U.S. climates, a U-value below 0.30 is considered good performance, the lower the number, the better the insulation. In colder zones, higher SHGC values can help capture winter sun; in warmer areas, lower SHGC helps keep interiors cooler.

Today's residential-grade vinyl and composite windows typically feature double-pane insulated glass filled with argon gas and coated with low-emissivity (Low-E) films to reflect infrared energy. This combination can roughly double efficiency of the window compared to basic glass and meet or exceed Energy Star standards in some regions.

Builders should note that Energy Star labeling is evolving, and required standards imposed through local codes increasingly define minimum energy performance by climate zone. A storage shed with a single-pane slider might be fine in an unheated space, but once a structure is used as a living area, office, or conditioned workspace, the windows must be National Fenestration Rating Council (NFRC) certified and meet the local residential energy code requirements. Failure to do so can complicate future resale or code inspection.

Beyond thermal numbers, material quality affects longevity. High-end vinyl resists UV fading thanks to titanium dioxide additives; lower-grade recycled vinyls can discolor or chalk over time. Aluminum joints that are screwed rather than welded can let in moisture, leading to oxidation at corners. Builders should verify construction details and warranties—many residential-grade vinyl windows now carry lifetime or double-lifetime warranties, including protection against fogging or seal failure.

Installation and Detailing

A high-quality window can still fail if it's installed poorly. Proper shimming, fastening, and sealing make the difference between a tight, long-lasting fit and a call-back months later.

Vinyl windows expand and contract



Harmony vinyl double hung with grids in the airspace and nail fin. PHOTO COURTESY OF AJ MANUFACTURING

with temperature, so they must be allowed to move slightly within the opening. Over-shimming or overtightening fasteners can distort the frame, especially in dark colors that absorb heat. Fasteners should be snug, not torqued down, and preferably set in slotted holes or secured with large-headed roofing nails. Shims belong under the window to create a solid foundation for the window to rest upon at key load points — under the bottom corners for double-hungs, thirds for sliders — so weight is evenly supported.

A common mistake passed down from installer to installer is not leaving shims under the frame in place and filling the gaps with expanding spray foam. The foam alone cannot support the window and as expansion and contraction cause the window to settle into the foam, it can create a bow in the window frame that may not show until months later. That subtle crown will throw the sash and frame out of square making it hard to open or seal properly. Use low-expansion foam designed specifically for windows and doors; it provides excellent insulation



ASTAAMERICA®

BY JANUS INTERNATIONAL

CARPORT AND SHED DOORS SHOULDN'T BE A CHORE.



YOU HAVE ENOUGH OF THOSE ALREADY.

ASTA America's roll-up carport and shed doors work just as hard as you do. Our superior quality commercial sheet doors are designed with spiral barrels for superior strength, tension holding devices, and factory lubricated springs for protection and smooth operation. **ASTA America's** roll-up doors get the job done every day, saving you money on repairs and maintenance. From smaller sheds to bigger carports, **ASTA America knows how to keep door maintenance off your to do list.**



ASTAAmerica.com

For more information on ASTA AMERICA and
our Doors, scan or call 770-974-2600.



PRODUCT FEATURE //

and creates a clean, effective seal. Apply it between the shims and around the rest of the window. Before fastening anything, make sure the window is properly leveled and plumb.

Flashing and trim details also separate a professional job from a problem job. Nail fins should be integrated with the wall's weather barrier, taped or rolled over the flange, and inspected before siding is installed. In metal walls, J-channel trim provides a clean, water-managed transition, but it must be sealed properly to prevent capillary leaks.

Whether flanged or flangeless, every window system should provide a drainage plane and protection against moisture intrusion at the sill. Euro-style flangeless systems, now appearing in higher-end post-frame builds, can reduce exposure to the elements and enhance performance if detailed correctly.

Common Pitfalls and Long-Term Value

The biggest installation errors come from skipping steps: not prepping the rough opening correctly, ignoring leveling and squaring, or mismatching window type to performance requirements.

When prepping the opening, remove debris including bits of dry wall and dried caulk. Adjust for fit; if the opening is too small, reframe it to fit. Make sure the window is plumb and level. Ensure the bottom edge of the opening is angled downward to the exterior so that water will flow away from the window.

If the window is not square, even slightly exceeding a tolerance of 1/32" can show visually or cause performance issues. Builders accustomed to single-pane ag windows sometimes underestimate the precision needed for modern, heavier, double-glazed residential units. Check the square of the window off the sash. Check the sash to the frame reveal by sliding the sash open 1/8" to be sure it will contact the frame perfectly when closed. The 1/8" reveal should be equal across the entire plane; if that 1/8" reveal is equal, you know the sash will seal properly to the



PHOTO COURTESY OF PLYCO

frame. Levels and squares are helpful but the most important thing about installing a window is that the sash closes and seals evenly and tightly to the frame.

Compatibility matters. Fasteners should be matched to the substrate — metal-to-metal or metal-to-wood — using manufacturer-specified sizes and coatings. In post-frame walls with horizontal girts, framing the opening with proper headers, king studs, and jacks ensures both strength and code compliance. For barndominiums that mix post-frame and 2×6 infill walls, box-frame or replacement-style windows can simplify detailing, especially with stucco or brick finishes.

Sealants and finishing compounds can make a difference in performance, too. A top-tier exterior sealant synthetic caulk can provide superior movement capability and weather resistance for trim joints, while 100% silicone is often sufficient for perimeter seals. The goal is flexibility—rigid sealants crack as the building expands and contracts.

Condensation is another consideration. Even the best glass will show moisture if interior humidity is high and exterior temperatures drop. Low-E coatings and argon fills help, but air circulation and humidity control inside the building are part of the solution. Windows need air movement and heat across the window plane because a warm window will not have condensation. Customers need to know that while ceiling fans and furnace fans move air, blinds or heavy drapery on windows can block the heat from

getting to the window, potentially leading to condensation. A fogged insulated window unit, however, usually means the perimeter seal has failed. Good manufacturers warrant against that for at least five years, often much longer.

In agricultural applications, durability may outweigh efficiency. In horse barns, tempered glass prevents dangerous shards if broken. Grilles mounted inside the glass can help keep animals from breaking glass or screens. In machine sheds, builders often choose robust aluminum-framed windows for impact resistance and ease of cleaning, while still maintaining a consistent exterior appearance with adjoining structures.

The Builder's Takeaway

Post-frame builders enjoy more flexibility than ever in window selection, but with that freedom comes responsibility. Every project—whether a hay barn, a horse arena, or a high-end residence—demands a clear understanding of how the window interacts with the structure, the environment, and the end use. Energy ratings, materials, and installation details all affect long-term performance.

In the end, the right window is the one that fits the building's purpose and stands up to its conditions. Match the specification to the function, use proper installation techniques, and pay attention to materials and warranties. Those small decisions make the difference between a building that merely looks good at handoff and one that performs well for decades. **FBN**



NAIL IT RIGHT EVERY TIME



Maze Premium Post Frame Nails



RUBBER WASHER NAILS

HARDENED POST & FRAMING NAILS

STORMGUARD® POST & FRAMING NAILS

STORMGUARD® JOIST HANGER NAILS



1.800.435.5949 | mazenails.com

NFBA Announces Event Details

The big news at this time, of course, is the industry is gearing up for Frame Building Expo, which will be held in Oklahoma City, February 25-27, 2026.

Over three days, the event will bring together builders, suppliers, manufacturers, designers, and engineers to share knowledge, explore new products, and build business relationships.

Attendees can take part in educational breakout sessions in areas such as business management, sales and marketing, technical topics, and safety.

The Expo floor features more than 150 exhibiting companies offering tools, materials, and innovations specifically for post-frame buildings.

There are also practical demonstrations, competitions (such as nail-driving), and networking receptions.

It's both an educational forum and a marketplace, helping industry stakeholders stay current on trends, technology, and regulation while making meaningful connections.

Show Location and Hotel

The 58th Annual NFBA Post Frame Expo will be held at the Oklahoma City Convention Center and Omni Hotel.

- Oklahoma City Convention Center
100 Mick Cornett Dr.
Oklahoma City, OK 73109-1101
- Omni Oklahoma City Hotel
100 Oklahoma City Blvd
Oklahoma City, OK 73109

The Room rate will be \$229 (single and double occupancy), \$249 (triple occupancy) and \$269 (quadruple occupancy)

+ taxes (currently 14.12%). Your Guest Room Rate includes complimentary deluxe WiFi in guest rooms and public spaces.

Rooms will be available at the Group Rate three days pre- and post-conference dates based on availability.

Book Your Room Online at <https://bookings.omnihotels.com/event/oklahoma-city/2026-nfba-conference-expo>

Room Block Closing Date: Friday, January 23, 2026 at 5 PM CT

Parking in Oklahoma City:

There is a parking garage and surface lot available at the Oklahoma City Convention Center. The current cost of parking is \$10 per vehicle. The Omni hotel also offers valet parking.

Registering

Register online at <https://www.nfba.org/aws/NFBA/pt/sp/building-expo>

Fax: Complete a separate registration form for each employee and fax all forms together to 937-278-0317.

Mail: Complete a separate registration form for each employee and mail them together to: NFBA, 7250 Poe Ave. Ste. 410, Dayton, OH 45414.

Phone: Get personalized support by calling 800-557-6957

Program Changes and Cancellations:

NFBA reserves the right to substitute speakers or to cancel and reschedule events due to any unforeseen circumstances. If NFBA must cancel a show, registrants will receive a full credit or refund of their paid registration fee. No refunds will be made for lodging, airfare, or any related expenses. **FBN**

WFBA To Hold Annual Conference February 3-4

Building of the Year

The WFBA's Building of the Year Awards honor outstanding post-frame craftsmanship and design by member builders. Each entry showcases innovation, functionality, and the beauty of wood-frame construction. Projects must include at least 50 percent post-frame construction and be completed within the eligibility period. Entrants submit descriptions, floor plans, and clear photos of both progress and completion. Winners are recognized at the WFBA Annual Conference, featured on the association's website, and promoted throughout the year as examples of post-frame excellence. The program

highlights the diverse applications of post-frame building—from agricultural and commercial to residential—and gives members an opportunity to demonstrate their expertise to peers, customers, and the broader construction industry.

Annual Conference Feb. 3-4

The 2026 WFBA Annual Conference, held February 3-4 in Wausau, Wisconsin, is the premier gathering for post-frame professionals. Attendees can expect two days filled with high-value education, technical sessions, product showcases, and networking events. The program features expert speakers covering engineering best

practices, new materials and codes, and emerging trends shaping the post-frame industry. Builders and suppliers will connect through roundtables, exhibitor interactions, and peer-to-peer discussions designed to spark innovation and share solutions to common challenges. The Conference also includes the annual awards dinner, where the Building of the Year winners are revealed and members celebrate the strength of Wisconsin's post-frame community.

For questions on either of the above topics, contact Emily Mandich at emandich@assnsoffice.com or (888) 294-0084. **FBN**

DRIPSTOP™

STOP THE DRIPPING FROM CONDENSATION

Tired of Customers complaining about a dripping roof?
**Let Dripstop™ solve your condensation problems
before they start.**

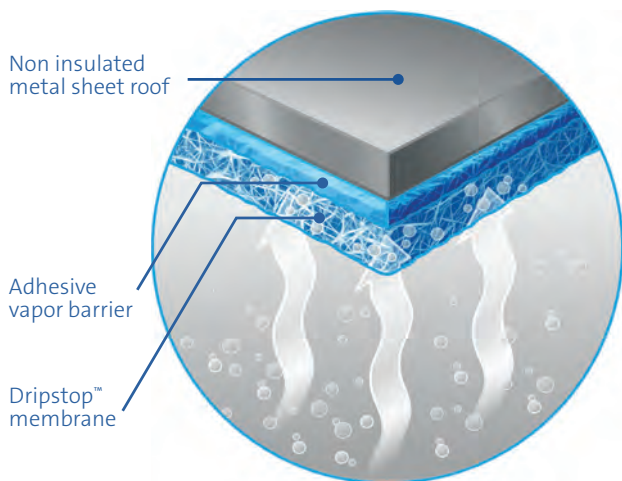

Dripstop™ is applied at the
time of roll forming

- ✓ Unmatched Durability
- ✓ Prevents Bird Nesting Issues
- ✓ Easy to Clean
- ✓ Maintenance Free
- ✓ Weather Resistant

Quicker - Easier - Cheaper
than other condensation control solutions



DRIPSTOP™

Ask for it from your preferred roof panel supplier.
www.dripstop.com or call us at: (937) 660-6646

Scan the code for more
information or to get in touch.

Frame Building Expo Schedule at a Glance

TUESDAY, FEBRUARY 24th

4-7 PM Registration

5-8 PM NFBA Certification Testing

WEDNESDAY, FEBRUARY 25th

7 AM-5 PM Registration

7-8:30 AM Breakfast

8-9 AM Educational Breakout Sessions

- **BUSINESS MANAGEMENT:** *Coaching for Success*, Eric Miner – Blunier Buildings
- **SALES AND MARKETING:** *Building Barndos: Opportunity or Headache?* Paul & Emily Marshall – Mr. Post Frame
- **SAFETY AND TECHNICAL KNOWLEDGE:** *Using Reflective Technologies to Improve the Thermal Performance of Your Building Envelope*, Monty Millspaugh - Reflective Insulation Manufacturers Association (RIMA)

9-9:15 AM Break

9:15-10:15 AM Educational Breakout Sessions

- **BUSINESS MANAGEMENT:** *Strategic Planning: Building Your Bench Strength*, Ed Krow - Ed Krow LLC
- **SALES AND MARKETING:** *Why Your Barndo Clients are Burning Out: Practical Processes to Master the Barndominium Cycle*, Olivia Berg - Back Forty Buildings, and Emily Marshall - Mr. Post Frame
- **SAFETY AND TECHNICAL KNOWLEDGE:** *Safety Best Practices & NFBA Resources That Can Help*
 - ♦ Gary Auman - Moderator
 - ♦ Todd Meinhold – H&D Quality Builders
 - ♦ Perry Lynch – Walters Buildings
 - ♦ Dave Underwood – FBI Buildings

10:15-10:45 AM Break

10:45 AM-12:45 PM KEYNOTE SPEAKER AND MEMBERSHIP MEETING

KEYNOTE PRESENTATION: *The Good, The Bad, & The Ugly: An Economic Update*, Dr. Anirban Basu - Chairman and CEO of Sage Policy Group (SPG), one of the Mid-Atlantic region's leading economic consultants.

1-5 PM EXPO OPEN

EXPO FLOOR ACTIVITIES

1:30-3:00 PM Shed Building Demo – Part 1

5-7 PM Women in Post Frame Meet N' Greet

8 PM-12 AM Plyco Reception

THURSDAY, FEBRUARY 26th

7 AM-5 PM Registration

7-8:30 AM Breakfast

8-9:00 AM Educational Breakout Sessions

- **BUSINESS MANAGEMENT:** *The Loyalty Crisis: Why Good Workers Leave & How to Make them Stay*, Lisa Ryan - Grategy
- **SALES AND MARKETING:** *The 5 Pillars of Empathy: Driving Growth & Collaboration in the Frame Building Industry*, Jevon Wooden - BrightMind Consulting Group
- **SAFETY AND TECHNICAL KNOWLEDGE:** *The 3-Hour Firewall*, Tim Royer - Timber Tech Engineering

9-9:10 AM Break

9:10-10:10 AM Educational Breakout Sessions

- **BUSINESS MANAGEMENT:** *Leadership - Part 1*, Pete McDowell & Peg Buehrle - ActionCoach
- **SALES AND MARKETING:** *How Executive Presence and Relationship Intelligence Drive Sales Excellence*, Jevon Wooden - BrightMind Consulting Group

- **SAFETY AND TECHNICAL KNOWLEDGE:** *Sealed & Certified: The Real Deal on Spray Foam for Post-Frame Construction*, Mike Dyna - X Spray Jones and Paul Marshall - Mr. Post Frame

10:10-10:20 AM Break

10:20-11:20 AM Educational Breakout Sessions

- **BUSINESS MANAGEMENT:** *Leadership - Part 2*, Pete McDowell & Peg Buehrle - ActionCoach
- **SALES AND MARKETING:** *7 Critical Brand Management Strategies You Shouldn't Ignore*
- **SAFETY AND TECHNICAL KNOWLEDGE:** *The AI-Powered Builder: How Smart Tech is Reshaping Construction and Business*, Kevin Fox - Foxwerx Group

11:20-11:45 AM Break

11:45 AM-1:15 PM Awards Luncheon (ticketed event)

12-4:30 PM EXPO OPEN

EXPO FLOOR ACTIVITIES

2-3 PM Shed Building Demo – Part 2

5-7 PM Christians in Construction Reception

7-10 PM Expo Social and Foundation Auction

FRIDAY, FEBRUARY 27th

8-10:30 AM Registration

8:30-10 AM Continental Breakfast

8:30 AM-12:30 PM EXPO OPEN

EXPO FLOOR ACTIVITIES

11-11:45 AM Nail-Driving Competition

12:00 PM Grand Prize Drawing

NATIONAL FRAME BUILDING ASSOCIATION PRESENTS

NFBA 58TH ANNUAL CONFERENCE & BUILDING EXPO

OKLAHOMA CITY OKLAHOMA

FEB 25 - 27 2026

THE PREMIER EVENT FOR THE POST-FRAME CONSTRUCTION INDUSTRY!

Come and connect with more than 2,000 builders, suppliers, distributors, academics, and code and design professionals serving the U.S. post-frame industry. Builder attendees come to learn about new products and new suppliers, evaluate their current buying needs, and make smarter purchasing decisions for their company.

- **Trade Show:** NFBA has a huge expo floor where exhibitors showcase new products, equipment, and services relevant to the post-frame industry.
- **Educational Sessions:** Seminars and workshops led by industry experts, focusing on business strategies, technical knowledge, sales and marketing and safety.
- **Networking and Community Building:** A chance for attendees to connect with fellow professionals, share information, and build relationships.
- **Industry Recognition:** Building of the Year, Crew Foreman of the Year, Company Safety, and the Bernon G. Perkins Post-Frame Industry Award will be presented at a special ceremony that honors this year's most deserving recipients.



ALONG WITH **FAMILY FUN ACTIVITIES!**

LOCATION:
Oklahoma City Convention Center
100 Mick Cornett Dr. Oklahoma City, OK 73109

PROUD SPONSORS

AkzoNobel

HIXWOOD

SHERWIN-WILLIAMS
Coil Coatings

CANNONBALL HNP, LLC

MWI
COMPONENTS

BURROWS
COMPLETE POST-FRAME SOLUTIONS

BUILDERS VISIT NFBA.ORG OR CALL 800-557-6957 FOR A FREE EXPO PASS!

2026 NFBA CONFERENCE & EXPO EXHIBITORS

Oklahoma City, OK
February 25-27, 2026

The Frame Building Expo in Oklahoma City, OK is a gathering of world-class goods and service providers for the post-frame industry.

Exhibitors and or booth spaces are subject to change.



Acu-Form

Booth #834

10550 Township Road 262
Millersburg, OH 44654
330-674-4003
330-674-4035 (fax)
wayne@acu-form.com
www.acuformequipment.com

Acu-Form has been the trusted name for premium roll-forming machines in the steel roofing industry. Our unwavering commitment to tried-and-true manufacturing processes, founded on proven design principles and strict quality control checks, sets the foundation for the Acu-Form promise — quality, reliability, and longevity. When you choose Acu-Form, you're choosing a partner dedicated to your success.



AJ Manufacturing, Inc.

Booth #851

1217 Oak St.
Bloomer, WI 54724
800-328-9448
715-568-3099 (fax)
vwachtendonk@ajdoor.com
www.ajdoor.com

A.J. Manufacturing builds high quality pre-painted or stainless steel walk doors. All doors are pre-hung in steel, aluminum

or stainless steel frames with 4" x 4.5" fixed pin hinges for 4-way universal swing even with a foamed in place door lite. A.J. also offers a complete line of high quality vinyl windows. Options include horizontal sliding, fixed lite, casement, single hung, and double hung windows with the patented EZ-v™ vinyl trim and flashing system.



Atlas Building Products

Booth #543

1628 Troy Rd.
Ashland, OH 44805
www.AtlasFasteners.com

Atlas Building Products, the industry leader, has the widest selection of metal and wood fasteners, closures, venting, sealing, flashing, and exterior building performance solutions. Headquartered in Ashland, Ohio with manufacturing and distribution located in Ohio, Texas, and North Carolina. Atlas is a member of the Marmon Group, a Berkshire Hathaway Company and part of the Marmon Fastener Company.



Bay Insulation Systems

Booth #735

PO Box 9229
2929 Walker Drive
Green Bay, WI 54308
920-406-4000
920-406-4242 (fax)
dtomchak@bayinsulation.com
www.bayinsulation.com

Bay Insulation Systems is a leading supplier of post frame insulation and systems in North America. With 25 facilities strategically located throughout the United States and Canada, our Experience, Quality and Service are second to none. At Bay, we use NAIMA 202-96 fiberglass blanket & superior quality vapor barriers to produce custom-laminated insulation that meets the NIA Certified Faced Insulation® Standard 404.2-2024.



Freudenberg Performance Materials LP

Booth #937

3500 Industrial Drive
Durham, NC 27704
503-871-5806
info@dripstop.com
www.dripstop.com

For over 25 years, Dripstop™ has been the absolute best way of dealing with condensation on non-insulated metal roofs. It has been tried and tested in every climate condition across the globe and has proven to be a simpler and more economical way. The membrane will absorb the water caused by condensation, thus preventing dripping from the roof. Dripstop™ serves as an added layer of protection for the metal in corrosive environments while also improving inside and outside acoustic properties.



FootingPad Post Footings

Booth #415

400 Carol Ann Lane
Ossian, IN 46777
800-522-2426
customerservice@footingpad.com
www.footingpad.com

FootingPad post foundations are the only tested and certified code compliant footings for use below grade to support posts and columns. Easy to transport and use, FootingPad saves valuable time and increases profits. FootingPad can be used under wood posts, laminated columns, Perma-Column and concrete piers. Sizing charts are available on footingpad.com to ensure you have the right FootingPad to support your building. Load capacity up to 9,327 lbs per footing.

Build Better. Build Stronger. Build to Last.

Certified Code Compliance. Guaranteed Quality.

As a professional builder, you need options to support your business. Our range of foundation solutions gives you the flexibility to meet every customer need and every project challenge.

Third-party testing ensures code compliance, consistent quality, and superior durability.



JOIN US AT THE NFBA SHOW
Booth 415 • Feb. 25-27

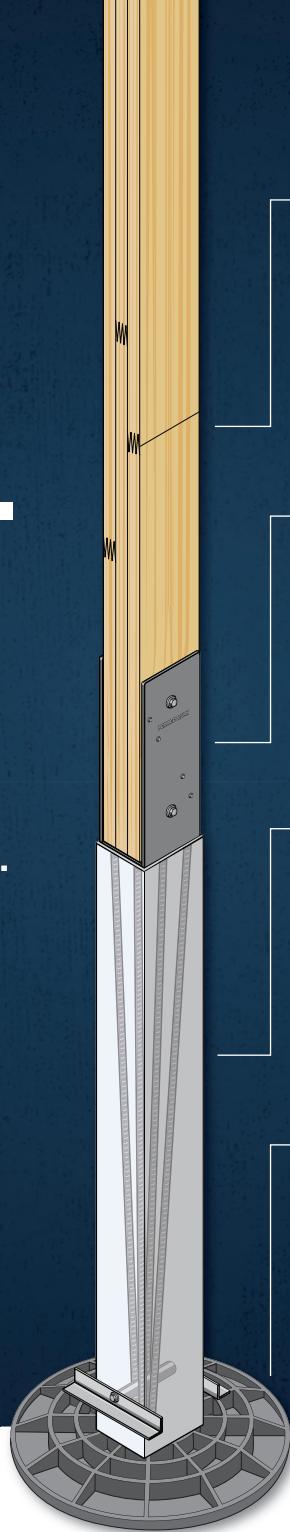

AITC-certified Glulam

Richland columns are engineered with staggered finger joints for maximum strength and superior load bearing. Available as KDAT SYP #1 or MSR lumber.

Robotically welded steel

Perma-Column® precast columns and Sturdi-Wall® anchor brackets feature American-made ¼-inch steel for maximum tensile and yield strength with a durable powder-coating.

10,000 PSI precast concrete

Perma-Column® precast columns with integrated steel brackets and rebar are three times stronger than standard concrete, elevating wood out of the ground to eliminate decay.

Fiber-reinforced composite

FootingPad® footings are lightweight, easy to handle, and engineered to match the load capacities of concrete at a fraction of the weight. Install faster without compromising strength or stability.

Scan for our full range
of foundation solutions



PERMA-COLUMN®
PRO-BUILDER SOLUTIONS



The post-frame performance experts | permacolumn.com/pro | 800-622-7192

2026 NFBA CONFERENCE & EXPO EXHIBITORS



Graber Post Buildings, Inc.

Booth #333

7716 N 900 E
Montgomery, IN 47558
800-264-5013
info@graberpost.com
www.graberpost.com

Graber Post Buildings is a leading distributor and manufacturer of post-frame and metal roofing supplies and materials. We roll-form 6 different metal panels, and we have a custom trim department that can produce almost any trim profile needed for your projects. We also produce nail-laminated columns and pre-engineered wood trusses up to 100' clear span. We also stock overhead doors, windows, sliding door components, cupolas, fasteners, underlayments, vapor barriers, insulation, and much more. A true 1-stop shop!



Hixwood

Booth #538

N14685 Copenhaver Ave.
Stanley, WI 54768
715-644-0765
715-644-0094 (fax)
www.hixwood.com

Hixwood is a leading provider of premium quality building products for the post-frame and metal roofing industry. We pride ourselves on providing products that meet your precise specifications - as well as your customers' demands for style, durability, and value. For full building packages, steel panel production, custom trim, coil, and industry expertise - Hixwood means QUALITY YOU CAN COUNT ON. Your trusted building materials manufacturer and supplier since 1998.



Leland Industries, Inc.

Booth #339

95 Commander Blvd.
Toronto, ON M1S3S9
Canada
www.lelandindustries.com

Leland manufactures a complete line of fasteners for the wood frame, metal roofing and steel frame industries. We are one of North America's largest manufacturers and suppliers to the post-frame market. We offer self-tapping and self-drilling sealing fasteners in lengths to 12 inches in #10, 12 and 14 diameters. Leland's fasteners are 100 percent North American made, in carbon or stainless steel and can be plated, coated or powder coated to match any panel color. Leland will match any steel painted panel warranty. NZF3000® Series Zinc-Flake plating will revolutionize corrosion protection. Hexavalent Chromium Free, ROHS and DFARS compliant.



Maze Nails

Booth #452

100 Church St.
Peru, IL 61354
800-435-5949
www.mazenails.com

Maze Nails is the exclusive manufacturer of Stormguard® double hot-dipped galvanized nails with a lifetime warranty against rust. In business since 1848, Maze offers a full line of specialty nails in bulk for hand driving and in collated sticks and coils for popular pneumatic nailers. Maze has been serving the post-frame industry for many years, providing painted rubber washer nails for corrugated roofing and siding. Maze post-frame nails meet ASTM F1667 specification. In addition, Maze manufactures nails for fiber cement

siding products, cedar and redwood sidings, fencing, decking and roofing. All Maze Nails are proudly 100% made in the USA.



MWI Components

Booth #327

1015 32nd Ave. W
Spencer, IA 51301
800-360-6467
800-361-3452 (fax)
info@mwicomponents.com
www.mwicomponents.com

Founded in 1985 in Spencer, Iowa, MWI Components manufactures and distributes high quality American made metal products for post frame construction. Serving all 50 states, we offer fast lead times, top tier service, and a wide range of components from sliding doors to ventilation, helping builders bring post frame visions to life.



Perma-Column, LLC

Booth #415

400 Carol Ann Ln.
Ossian, IN 46777
800-622-7190
www.permacolumn.com
www.richlandcolumns.com
www.footingpad.com

We're your single source for today's most reliable foundation products. Tested, certified, and proven, our family of brands gives builders a competitive advantage. We manufacture and supply Richland AITC-certified Glulam and Nail-Lam columns, FootingPad® composite footings, Perma-Column® precast concrete columns and skirt boards, precast concrete deck posts, as well as Sturdi-Wall® and Sturdi-Wall® Plus anchor brackets. Code compliance, verified through independent third-party testing, ensures that your selected foundation adheres to industry standards for quality and durability.

SUBSCRIBE NOW!



BuildMyBarndo.com, a website dedicated to people considering building a barndominium.

Shield Wall Media brands are dedicated to serving the information needs of construction professionals.



SUBSCRIBE ONLINE: shieldwallmedia.com/subscribe or fill out & mail form below.



FREE 3-YEAR SUBSCRIPTIONS!

1. Please check one or more boxes, sign & date:

I wish to receive: Metal Roofing Plain Builder Metal Builder Rural Builder
 Frame Building News Rollforming Roofing Elements BuildMyBarndo.com (digital only)

Signature (REQUIRED): _____ Date: _____

Print Name: _____

Company: _____

Address: _____

City/State/Zip: _____

Phone or Email (REQUIRED): _____

Check this box if you wish to receive the email newsletter associated with the magazine subscription(s) above.

2. Choose which title applies:
 President/Vice President
 Principle/Shareholder
 Sales Manager or Rep
 Foreman/Crew Manager
 Engineer/Architect
 Other: _____

3. Describe your business:
 Builder/Contractor
 Dealer/Distributor
 Manufacturer
 Engineer/Architect
 Other: _____

I would like to receive my subscription:
 By Mail
 Digitally

SWM2026

4. Please check all of the types of building or manufacturing you are involved with:

- | | | | |
|---------------------------------------|--------------------------------------|---|---|
| <input type="checkbox"/> Post Frame | <input type="checkbox"/> Residential | <input type="checkbox"/> Metal Roofing | <input type="checkbox"/> Rollforming |
| <input type="checkbox"/> Metal Frame | <input type="checkbox"/> Commercial | <input type="checkbox"/> Trusses/Columns | <input type="checkbox"/> Trim & Flashings |
| <input type="checkbox"/> Fabric | <input type="checkbox"/> Equine | <input type="checkbox"/> Foundations | <input type="checkbox"/> Insulation/ |
| <input type="checkbox"/> Agricultural | <input type="checkbox"/> Roofing | <input type="checkbox"/> Gutters/Snow Retention | <input type="checkbox"/> Moisture Control |



MAIL TO:
 Shield Wall Media
 ATTN: Barb Prill
 PO Box 255, Iola, WI 54945

2026 NFBA CONFERENCE & EXPO EXHIBITORS



Pine Hill Trailers

Booth #846

5140 Martin Dr.
Gap, PA 17527
717-288-2443
888-897-1925
717-288-2436 (fax)
sales@pinehilltrailers.com
www.pinehilltrailers.com

From custom trailers to expert services and premium parts, Pine Hill is dedicated to Moving You Forward. We provide innovative, durable solutions with a focus on efficiency and top-tier craftsmanship. When you demand quality and reliability, you can trust Pine Hill to deliver the best in the industry.

PLAIN BUILDER

Plain Builder Magazine

Booth #351

PO Box 255
Iola, WI 54945
715-952-1657 (Gary, advertising)
715-952-1633 (Karen, editor)
karen@shieldwallmedia.com
www.plainbuilder.com

Plain Builder is a business-to-business publication that covers the news, companies, products, and information for construction professionals in or doing business with the Plain Communities. This includes post-frame, cold-formed steel, roofing, roll forming as well as other types of construction and construction-related manufacturing. Plain Builder recognizes the vital and increasing contribution the Plain Community makes to the construction industry. For advertising opportunities email gary@shieldwallmedia.com.



Plyco Corporation / East Coast Fasteners

Booth #601

500 Industrial Drive

Elkhart Lake, WI 53020
800-558-5895
marketing@plyco.com
www.plyco.com

For over 70 years, Plyco has been a leading supplier of products to the post-frame, metal clad building and commercial construction industries. Providing metal doors, windows, horse stall systems, ventilation products, reflective insulation, fasteners and closures, and more.



PowerLift Hydraulic Doors

Booth #218

www.powerliftdoors.com

PowerLift has built hydraulic doors continuously since 1992. It has 45+ local support centers that manufacture, deliver, and install every single door. PowerLift strives to make your building project and your long-term ownership experience simple and hassle free.



Rigidply Rafters

Booth #536

PA Location
701 E. Linden St.
Richland, PA 17087
717-866-6581
www.rigidply.com

MD Location
1283 Joni Miller Rd.
Oakland, MD 21550
301-334-3977
www.rigidply.com/oakland

Rigidply Rafters has improved the quality of post-frame buildings by manufacturing and distributing the original 100% glue laminated post. By specifying Rigidply Posts, you guarantee the labor-saving and quality advantages of true glulam posts. Not only are glulam posts lighter, straighter, and stronger, but they minimize cracking and splitting. When planning your next building project, Rigidply Rafters promises to supply

integrity, quality, and service with your glulam posts.



Steel Dynamics, Inc.

Booth #615

7575 West Jefferson Blvd.
Fort Wayne, IN 46804
615-429-0751
www.steeldynamics.com

SDI Flat Roll Group operates 3 EAF melt shops, 13 metallic coating lines, and 6 paint lines, with locations in Indiana, Pennsylvania, Mississippi, and Texas. Products include painted Galvalume® and Galvanized, Hot Rolled and Cold Rolled bare, plate, and Digital Print steel.

SHIELD WALL MEDIA EVENTS

POST-FRAME ■ RURAL ■ PLAIN BUILDER SHOW

The Post Frame Builder Show has expanded for 2026 and now includes both the Rural and Plain Builder segments. This show encompasses all non-high-rise construction. Slated this year for June 10-11, the business-to-business event will bring buyers and vendors together at the York Expo Center in York, PA.

Construction Rollforming Show

Scheduled for September 16-17 in the beautiful city of Gatlinburg, TN the Construction Rollforming Show is the only show dedicated to rollforming and metal forming light gauge metal for the construction industry. In addition to rollforming, exhibitors include companies specializing not only in metal construction and accessories but also those supporting the construction industry in general.

For more information on exhibiting at a Shield Wall Media event, contact Event Director Missy Beyer at Tel: 715-350-6658 FAX: 715-227-8680 Email: missy@shieldwallmedia.com

To check out all of Shield Wall Media's offerings visit www.shieldwallmedia.com

REGISTER NOW TO ATTEND!



3RD ANNUAL

**POST-FRAME ■ RURAL ■ PLAIN
BUILDER  SHOW**

June 10-11, 2026

York Expo Center • York, PA



**FOR EXHIBITOR INFORMATION CONTACT MISSY BEYER:
missy@shieldwallmedia.com • 715-350-6658
FAX 1-715-227-8680**

**REGISTER TO ATTEND: COMPLETE & MAIL THIS FORM WITH PAYMENT,
OR REGISTER ONLINE AT:
www.postframebuildersshow.com**

3RD ANNUAL POST-FRAME BUILDER SHOW

Please fill out and mail with payment by May 11th to: **PFBS Registration, P.O. Box 255, Iola, WI 54945.**

(Please Print)

Name(s): _____

Company: _____

Address: _____

City/State/Zip: _____

Phone (required): _____

Email: _____

**ADMISSION FEE:
\$50.00 PER PERSON**

Quantity: _____

Total Enclosed: \$ _____

Make checks payable to: Shield Wall Media

Tickets also available at the door.

Post-Frame Problem Solvers

Find these and more post-frame products at Frame Building Expo 2026

■ By Karen Knapstein

The 58th Annual NFBA Conference and Expo takes place at the Oklahoma Convention Center from February 25-27, 2026. More than 150 companies will fill the expo space in Oklahoma City, including A.J. Manufacturing, ASC Machine Tools, Plyco Corp., MWI Components, and many more.

Builders can walk the Expo floor free of charge; free Expo passes are good for any individual engaged in the business of constructing post-frame buildings.

Here is a preview of a few of the materials and components you'll find on the Expo floor.



Booth 851: AJ Manufacturing bi-fold access door.

AJ Manufacturing (Booth 851) is exhibiting its energy-efficient ceiling access doors pre-hung in self-flashing, fully weather stripped frames. The 24" x 36" and 24" x 48" doors are available in 4" and 6" panel thicknesses. The 4" doors offer R-24 insulating value while 6" thick panels are R-42. Doors are shipped with egress handles. Bifold doors include hold-open struts. Ceiling Access doors can be installed with the Patent Pending Insulation Dam Kits fabricated out of 24-gauge steel that can manage up to 20" of blown cellulose or fiberglass batt insulation.

AkzoNobel Coil & Extrusion Coatings (Booth 744) is exhibiting its CERAM-A-STAR® Select program, which now features CERAM-A-STAR® Select Expressions finishes, bringing new design possibilities. Built on the advanced CERAM-A-STAR® 1050 platform, CERAM-A-STAR® Select Expressions combines the visual appeal of textured prints with a high-performance SMP finish. This unique technology makes it possible to achieve distinctive looks such as wood, slate, or granite while maintaining color stability and lasting protection.



Booth 744: AkzoNobel Coil & Extrusion Coatings CERAM-A-STAR® Select.



Booth 632: ASC Machine Tools F&J Trim Rollformer.

ASC Machine Tools (Booth 632) will be teaching attendees about the ASC F&J Trim Rollformer. ASC offers hand-fed and coil-fed F&J Trim Rollforming Lines with an optional feature allowing the production of two different soffit opening sizes. All lines feature cast rollformer stands and cast bearings blocks, quick access swing safety guard and much more.

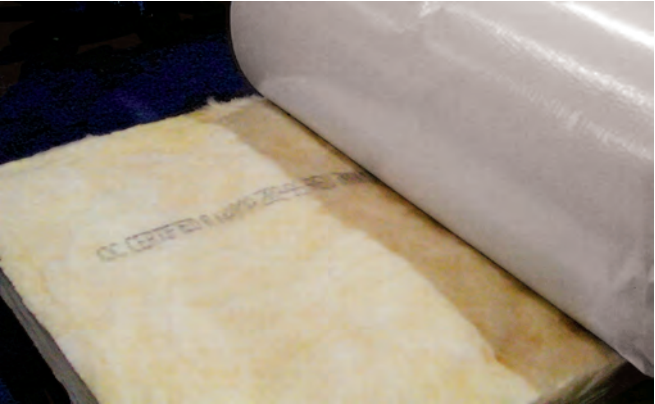

Booth 735: Bay Insulation Systems fiberglass insulation.

Bay Insulation Systems (Booth 735) manufactures and provides laminated/faced fiberglass insulation in R-values ranging from R-8 to R-32.5, in widths ranging from 36” to 96”, and in customized lengths to fit your post-frame building’s needs. The product is manufactured using superior quality vapor

barriers that are adhered to a NAIMA 202-96 fiberglass blanket. The final product meets the NIA Certified Faced Insulation® Standard 404.2-2024.



Booth 842: GitEstimate post-frame building estimation software.

GitEstimate (Booth 842) will demonstrate post-frame building estimation software. GitEstimate is a web-based software tool for post-frame and pole barn builders, enabling quick generation of cost estimates for standard designs without

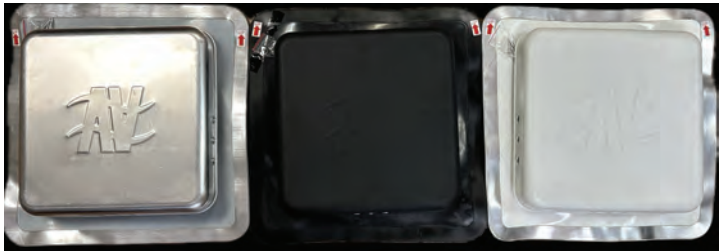

U.S. Patent #10907358 & 11649635

Roof vents designed specifically for metal roofing!

Currently available in Silver/Gray, Black/Black, and White/White.

Additional colors are on the way!

ARCHIE VENTS™

A brand by Golden Rule Fasteners, Inc.



PRODUCT FEATURE //

requiring expertise. It features company branding, customizable pricing for labor and materials, detailed parts lists with shipping weights, and an admin portal for managing submitted and saved estimates. The tool supports metal and wood trusses, handles common requests efficiently, and now includes 3D visualization for design representation.



Booth 751: Haas Door American Tradition Series garage doors.

Haas Door (Booth 751) is exhibiting its American Tradition™ Series, featuring steel door models in several thicknesses, and a recently introduced a 2 $\frac{3}{8}$ " corrosion-resistant aluminum door. This Series is available in 42 models that use overlay boards to create a realistic depth to the door. The models also include flush or v-groove panel styles, inverted options, and models that allow up to 2 lite sections. Both steel thicknesses are available in 10 solid and five wood grain color options, with fifteen matching overlay colors. The 2 $\frac{3}{8}$ " thick aluminum door is available in Polar White, Sandstone, and Carbon Black, which can be mixed and matched with the overlay color choices. The 2 $\frac{3}{8}$ " thick steel models have the highest thermal performance, with a U-Factor of 0.081. The joints between the sections also feature a bulb seal that meets code requirements for air infiltration.



Booth 738: McElroy Metal Nostalgia Panel.

McElroy Metal (Booth 738), will exhibit the Nostalgia Panel, which blends timeless beauty with modern practicality. Designed to capture the warmth and character of traditional wood siding, it offers homeowners and builders the charm of classic craftsmanship—without the drawbacks. Unlike natural wood, the Nostalgia Panel won't warp, rot, or invite pests, and it eliminates the constant need for repainting or sealing. Its durable metal construction ensures long-lasting performance and enduring curb appeal. The Nostalgia Panel delivers a smart, low-maintenance solution that preserves the look of yesterday while meeting the efficiency and sustainability demands of today.



Booth 215: Plasti-Sleeve Post Protection post and skirt board barriers.

Plasti-Sleeve Post Protection (Booth 215) will teach attendees about its clean fitting, easy-to-use, slide-on post and skirt board protection sleeves that provide the economical protection many post-frame customers now expect. The Plasti-Sleeve product line includes 22 specialized sizes for Plasti-Sleeve, Plasti-Skirt, an easy-to-use plastic skirt board/grade plank protector, and the economical Short-Sleeve post protector.

Plyco Corp. (Booth 601): New for 2026, Plyco will be introducing a line of high-quality fiberglass entry doors. We believe the market will appreciate these hybrid doors, which will be stronger and more durable than traditional composites. The fiberglass doors will be available in two frame systems: our heavy-duty 16 gauge steel frame, as well as our thermal break aluminum 92 frame. The fiberglass panels will be available in smooth and woodgrain embossed profiles in popular designs; with some having direct set glass options. The 60 series will be available in



Booth 601: Plyco Corp. Fiberglass Entry Doors.

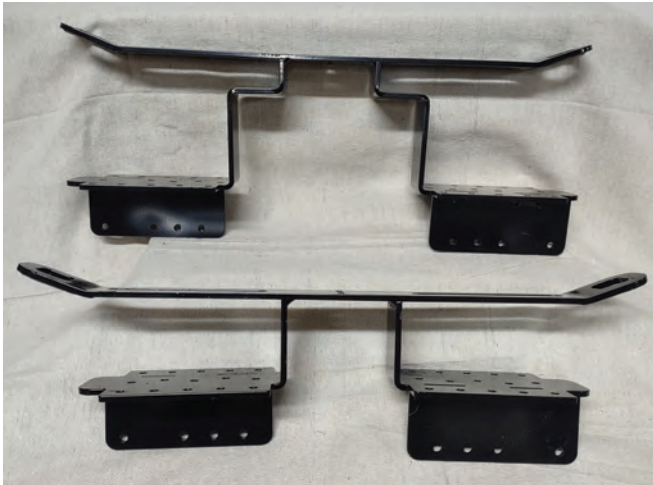

Booth 733: Ridgeline Safety Systems roof ridge anchors.



Booth 536: Rigidply Rafters Glulam Posts.

pre-painted white and black frames-doors, while the Designer FG Series will have more enhancements available to really bring your project to life and add curb appeal.

Ridgeline Safety Systems (Booth 733) provides permanent Exposed Tab roof anchors that are built to protect and save lives. Lives are priceless. Can you afford NOT to use them?

LELAND Specialty Fasteners

Master Grippers® Grippers MDP®



For the post frame building industry
MDP metal panel to wood or light steel girt or purlin.

Master Tappers®



Roof panel to panel - roof sheet to structural A - AB - B points available, type F, type 23, type 1, BP & more. Lengths to 8" available.

AVAILABLE: A325 STRUCTURAL BOLTS
A325 Heavy Hex Structural Bolts assembled and unassembled in our convenient 1/4 Keg Pails. Manufactured in 1/2", 5/8" & 3/4" diameters in lengths from 1-1/4" to 6".

Master Drillers®



Attach metal panel to metal girt or purlin, stitching & structural applications. Lengths to 8" available.

Powder Coating

No FADING • No CHIPPING



Our Powder Coated paint system allows us to match your painted steel supplier's warranty.



Made in Canada



1.800.263.3393
www.lelandindustries.com



Gold Key of Excellence Award Winner



2026 NFBA CONFERENCE & EXPO BOOTH # 339



METAL ROOFING METAL OF HONOR 2025

PRODUCT FEATURE //

Rigidply Rafters' (Booth 536) Glulam Posts deliver strength, straightness, and stability you can trust. Crafted with proven 0.60 PCF CCA treatment for lasting protection, these posts resist rot and decay for decades of reliable performance. Each laminated post acts as a single, solid structural unit—lighter, stronger, and straighter than traditional timbers. Our wet-use, structural-grade adhesive is stronger than the wood itself, ensuring long-term durability with no gapping or shrinkage. Every Rigidply Glulam Post is precision-engineered and quality-tested under AITC inspection—so you can build with confidence. Made with precision. Backed by history. Designed to perform.

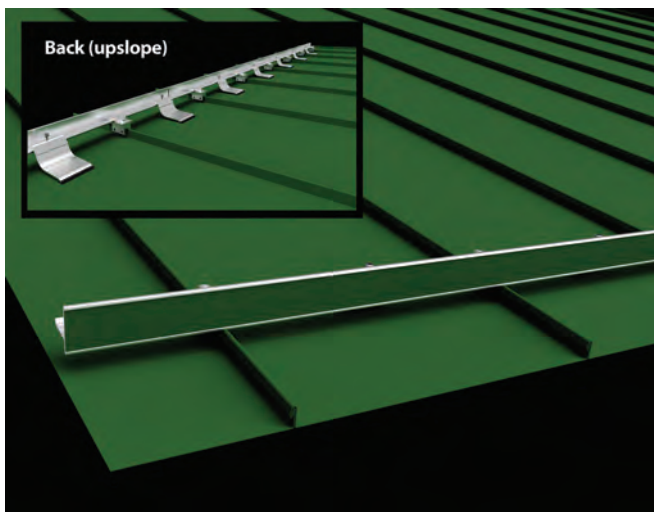

Booth 743: S-5! ColorGard® 2.0.

S-5! (Booth 743): After 30 years and 18,000 linear miles of proven performance, S-5!'s ColorGard® 2.0 sets a new benchmark in snow retention. Engineered for virtually all metal roof types, it delivers greater versatility, simplified assembly and faster installation. The system's true lay-and-play design requires no preassembly, saving time and effort on-site. Now a three-time industry award winner, ColorGard 2.0 features an innovative internal splice that fits directly over S-5! clamps and brackets—saving time and eliminating the need for cutting (except at the end of the assembly). The system dramatically reduces the risk of rooftop avalanches, ensuring reliable protection and peace of mind.

SWI Machinery will be exhibiting the Marxman Plus Slitter in **booth 301**. Based on the original Marxman, this machine has automatic nesting with 8 pairs of auto-setting slitter blades. It can run up to 150' per minute on 49" coils. No burrs, virtually no wasted material, and extremely accurate slits. Coupled with a 21.5" touchscreen interface and back-office integration capabilities, the Marxman Plus is an efficient, easy-to-use, and reliable sheet metal blanking machine – ideal for feeding rollforming and long folding operations.



Booth 301: SWI Machinery Marxman Plus Slitter.



Booth 309: Trac-Rite steel roll-up doors.

Trac-Rite (Booth 309) is a 100% employee-owned company with over 40 years of experience, proudly recognized as one of North America's most trusted door manufacturers. Learn about the company's high-quality, 100% American-made steel roll-up doors designed specifically for sheds, garages, carports, and other frame building applications. Our commitment to excellence extends beyond doors—we also provide all necessary components to support your construction projects, ensuring a seamless, worry-free process. With a legacy of durability, reliability, and unmatched customer service, Trac-Rite is your trusted partner for superior frame building solutions.

United Steel Supply (Booth 621) is excited to offer Tru-Steel HD® digitally-printed steel! This innovative product uses a high-resolution digital printer to transfer images of real wood onto



Booth 621: Tru-Steel HD digitally-printed steel. Pattern shown above: Smooth Cedar.

sustainable, USA-melted steel sheet.

Tru-Steel HD® patterns don't repeat for up to 32 feet, allowing for the inclusion of intricate woodgrain details such as knots and

cracks. Tru-Steel HD® is available in coil form or cut-to-length sheet from all United Steel Supply locations. It is easily rollformed into any siding, soffit, or trim profile, making it perfect for your next barndominium build! Now available in over 12 unique patterns!

The best place to learn about solutions to your post-frame challenges is the trade show floor. Find them in person during Frame Building Expo at the Oklahoma Convention Center February 25-27, 2026. **FBN**

To share your news announcements with Frame Building News readers, send them to editor Karen Knapstein at karen@shieldwallmedia.com.

Since 1951

Performance in Post Frame

Plyco's complete line of products surpasses building codes and customer expectations through stringent testing and quality standards.



PLYCOTM
CORPORATION

800.558.5895 • plyco.com



Great Habits to Start Off the New Year

January doesn't care about your resolutions. It cares about frozen ground, delayed deliveries, and crews trying to warm up their hands before swinging a hammer. That's why the best habits to start a year aren't big declarations. They're the small, steady moves you build into your routine.

I've seen too many years start with a burst of energy, only to fizzle by mid-February. Builders, suppliers, reps — we're all guilty. The folks who separate themselves aren't the ones who yell the loudest about "new year, new me." They're the ones who quietly stack wins every day.

Stack Your Wins

A win doesn't always look like a signed contract. It might be a clean safety record for the month. A young crew member learning to drive a screw straight. A supplier who delivers on time because you kept communication tight. Stack those wins. They compound.

The same goes outside of business. Getting your walk in before daylight? Win. Turning down the second helping when you didn't need it? Win. Saying yes to family time instead of more paperwork? Big win. These stack up into the kind of momentum that carries a business season and a life forward.

Build the Right Business Habits

Builders know the work doesn't stop because the calendar flipped. That's why the right business habits matter. Here are a few to lock in early:

- **Tradeshows and seminars.** Don't just walk the aisles. Block out time for at least one educational session. The guys who



When attending trade shows, block out time to attend at least one educational session. SHIELD WALL MEDIA PHOTO.

learn early in the year are the ones solving problems mid-season.

- **Routine safety and sales meetings.** Ten minutes at the start of the week keeps everyone on the same page and prevents small issues from growing into big ones.

"A win doesn't always look like a signed contract. It might be a clean safety record, a straight screw, or a supplier who delivers on time. Stack those wins. They compound."

— Randy Chaffee

- **Equipment maintenance.** Grease the hinges, change the filters, sharpen the blades before you need them. Downtime in July's a lot more expensive than an hour in January.

- **Onboard early.** New hires don't learn best under fire. Bring 'em in now while the

pace is slower. Teach them right, let them get their footing.

- **Supplier check-ins.** Long lead times and material gaps sink projects. Call ahead, meet early, and get your ducks in a row now instead of waiting for crunch time.

These aren't glamorous, but they're the difference between professionals and seat-of-the-pants operators.

Keep the Personal Side Sharp

If your body and mind are running on fumes, it doesn't matter how sharp your take-off numbers look. Health, fitness, and spiritual habits aren't "extras." They're the fuel.

- **Move daily.** Whether it's a morning walk, gym session, or just getting out of the truck and stretching at job sites, motion keeps you sharp.

- **Eat like you need energy, not comfort.**

Builders burn calories, but sloppy eating catches up faster than you think.

• **Quiet time.** For some it's prayer, for others it's reading or reflection. Either way, it steadies your mind before you face the noise.

These habits keep you resilient when the season gets hard.

Show Up with Intent

Showing up with intent isn't about hype or chasing a perfect day. It's about being steady. Some mornings the weather's bad, orders are late, and crews are dragging. Intent means you still walk in ready to lead, ready to adapt, and ready to do the work right.

We don't get a practice run. Every day matters. Showing up with intent isn't about pep talks. It's about stacking small, steady wins. Do the work with purpose, take care of your people, and the rest follows.

Tie It Together

The strongest builders and suppliers I know don't separate personal from professional. They see the connection. A fitter body makes for a sharper leader. A steady business habit builds confidence that spills into family life. A small win at home fuels a bigger win on the job site.

Habits don't silo. They weave together. That's why starting the year with the right mix matters more than big speeches or lofty resolutions.

Closing

This industry doesn't reward shortcuts. It rewards those who stack the right habits, day after day, through every season.

That's why I wrote *Asphalt and Algorithms* — to put into words the lessons of a life spent pounding miles, shaking hands, and now adapting to a hybrid world. The tools change. The

ground shifts. But habits? Habits carry you through.

Show up with intent. Stack your wins. Take care of your people. And keep building the kind of year you'll be proud of when December rolls back around. **FBN**

Randy Chaffee brings four-plus decades of experience to the post-frame and metal roofing industries. Author of #1 Amazon Best Seller "Asphalt and Algorithms," he is a board member for the Buckeye Frame Builders Association and the National Frame Builders Association. Find his podcast at facebook.com/BuildingWins or call (814) 906-0001 at 1 p.m. Eastern on Mondays to listen in.



THE PINE HILL MATERIAL SERIES

For unmatched performance in material transport with complete remote-controlled functionality

FEATURES

Wireless Remote-Controlled | Sliding Straps
Tongue & Tail Extension | Dexter Torflex Axles
Center Tie-Down Rail | 12V Hydraulic System
Disc Brakes | Hydraulic Jack | Corsol Corrosion Solutions (field-proven corrosion protection)

ADD-ONS & UPGRADES

Sideway Wheels | Aluminum Wheels
Gooseneck | **Truss Package**

SMART ROLLERS MEANS SMARTER HAULING — UNLOAD WITH ONE PERSON, ZERO HASSLE.



PLUS AN ALL-NEW TRUSS UPGRADE



Hauls Trusses Up to 70'

717.288.2443 | 5140 MARTIN DRIVE, GAP, PA 17527 | PINEHILLTRAILERS.COM

Building Interest In the Trades

Welcome to the January 2026 edition of Frame Building News. This is the Frame Building Expo edition of Frame Building News. You'll find us in booth 351. But we'll most likely be wandering around the Expo floor. Wherever you see us, please ask us about Max Builds.

Max Builds is a series of children's books designed to introduce kids to the construction trades. The official Shield Wall Media office dog decided to document his career in construction. These books are the result.

The first book is Max Builds a Metal Roof. The second is Max Builds a Pole Barn, which we'll be handing out at Frame Building Expo. We plan to release one book per quarter. Each new book will focus a type of construction covered in our magazines.

We are giving these books away. If you want one or two for family or a few to give out to your local libraries and schools, let us know. This is a chance for us to share our love of the construction trades with kids and introduce them to a viable career path.

Please help us get the books out, and if you are concerned about the number of people choosing a career in the trades ask me about sponsorship opportunities.

Let's make Max famous. **FBN**

Gary Reichert, Publisher
Shield Wall Media

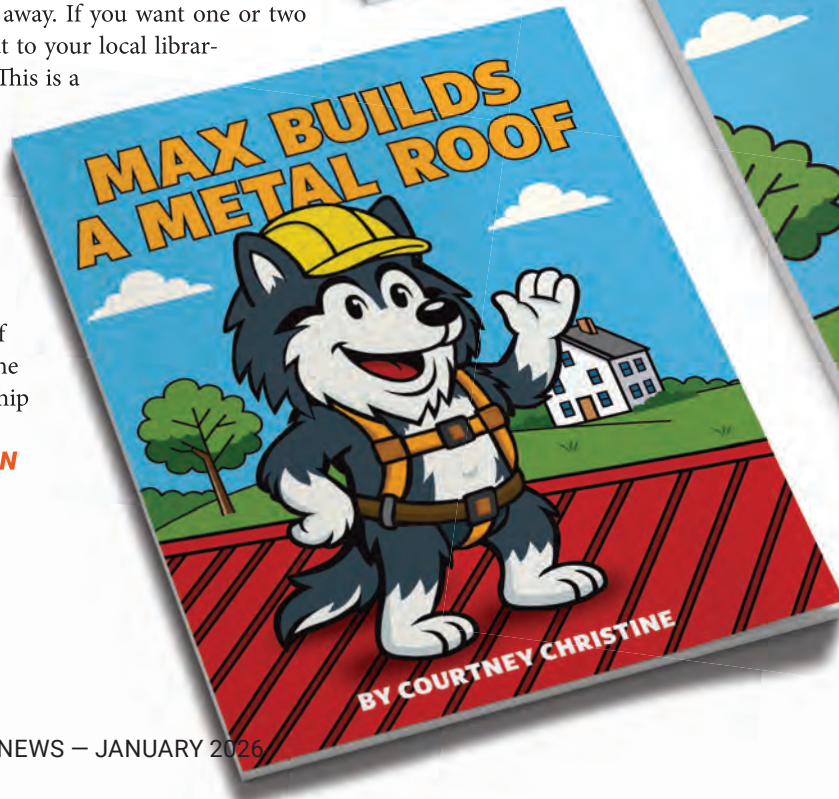



Reskinning a Pole Barn

Giving an Old Building a New Lease on Life

■ By Courtney Glover

According to Greiner Buildings, reskinning a pole barn is one of the most efficient ways to save time, money, and stress when maintaining or modernizing a post-frame building. Over time, exposure to the elements can cause even the sturdiest structures to show signs of wear. Instead of demolishing the existing building and starting from scratch, reskinning allows owners to revitalize their investment by upgrading its appearance, durability, and functionality—using the structure they already have.

What Is Reskinning?

A building “recover” or reskin is essentially a remodel of an existing post-frame building. By utilizing the current framework, the process replaces the entire exterior—typically the steel siding and metal roofing—while maintaining the original bones of the structure. This major renovation transforms the look of the



Steel is the most popular choice for reskinning an existing post-frame building.



PHOTO COURTESY OF FBI BUILDINGS, INC.



Before beginning a reskin, it is essential to evaluate the existing structure's integrity.
PHOTO COURTESY OF KINETIKA

building, improves weather resistance, and seals out drafts or leaks. Projects are often completed in 30 days or less, offering a fresh, modern appearance without the high cost or extended timeline of new construction. If the structure remains sound, a reskin is often the smartest and most sustainable option.

Cost Efficiency

One of the main advantages of reskinning is its affordability. Greiner estimates that most projects cost only about one-third of what a full rebuild would require. The final price depends on factors such as building size, chosen

materials, and added upgrades. Common enhancements include lean-tos, overhangs, cupolas, or updated insulation. Overall, reskinning delivers substantial savings in both labor and materials while extending the lifespan of the building.

Material Options

Selecting the right material is key to achieving both aesthetic appeal and long-term performance.



PanelVent™



U.S. Patent #11946263

Roof vents designed specifically for metal roofing!

Currently available in Black.

Additional colors are on the way!

ARCHIE VENTS™

A brand by Golden Rule Fasteners, Inc.



Ph: (334) 283-4030 Fax: (334) 283-4032 Email: info@goldenrulefastenersinc.com

CLOSER LOOK //

- **Steel Siding:** The most popular choice, steel offers outstanding weather resistance and a wide range of color options. It is easy to install, durable, and low-maintenance. However, it can be dented by heavy equipment and may rust if the protective coating is compromised.

- **Engineered Wood:** This material provides a warm, traditional look that closely mimics natural wood. While beautiful, it may require more upkeep and can be susceptible to moisture damage.

- **Stone or Stone Veneer:** For a premium finish, stone adds elegance and curb appeal. It can be used as a full façade or decorative accent. However, it is significantly more expensive and labor-intensive to install compared to steel or wood.

Ultimately, the best material depends on your design preferences, maintenance expectations, and overall budget.

Inspecting the Structure

Before beginning a reskin, it is essential to evaluate the existing structure's integrity. Inspect all framing, trusses, and posts for rot, warping, or other damage. Any structural issues should be repaired before new materials are installed. Failing to address these problems can lead to concealed damage and reduce the effectiveness of the renovation. A solid foundation ensures that your investment lasts for years to come.

Permitting Requirements

Depending on your location, you may need one or more permits before starting a reskin project. These ensure compliance with local building codes and safety standards. Requirements can vary but may include zoning approval, structural modification permits, or a site plan review. While reskinning often avoids the major costs associated with a full rebuild, it is always best to verify local regulations before beginning construction.

Preparing the Site

Proper site preparation sets the stage for an efficient remodel. Clear the area



When the building perimeter is clear, it helps prevent delays and ensures a clean, safe workspace throughout the project.

surrounding the barn—typically at least three feet from the perimeter—of all vegetation, debris, or obstacles. Designate a staging area for materials and equipment. This helps prevent delays and ensures a clean, safe workspace throughout the project.

Planning and Measuring

Accurate measurements are crucial to a successful reskin. Begin by surveying the existing structure, noting all exterior dimensions, elevations, and features. Many builders use CAD (Computer-Aided Design) models to map the project precisely, which aids in estimating materials, planning logistics, and staying within budget.

Removing the Old Exterior

Once the site is ready, remove all existing panels, screws, and fasteners holding the old siding or roofing in place. Carefully dispose of or recycle materials as appropriate. Clean the underlying frame to remove dirt, rust, and debris before new installation begins.

Installing the New Skin

Start with the roofing panels, ensuring proper overlap and watertight seals to prevent leaks. Then, install the

siding panels, beginning at one corner and working methodically across the structure. Use appropriate fasteners and align panels evenly for a professional finish. Seal all seams and joints with high-quality silicone caulking to block moisture and drafts. When complete, wash and inspect the surface to remove residue and ensure a polished, long-lasting result.

Conclusion

Reskinning a pole barn breathes new life into an existing structure—transforming an aging building into one that looks brand new. It provides a cost-effective, eco-friendly, and efficient alternative to complete reconstruction. With proper planning, material selection, and installation, a reskin can dramatically improve both the appearance and performance of your building. Before you decide to tear down that weathered structure, consider giving it a second life through reskinning. **FBN**

Courtney Glover is a freelance writer and photographer based in Milwaukee, Wisconsin. She contributes her talents to various publications and is the author of “Max Builds A Pole Barn” the second book in the Shield Wall Media children’s book series.

Family Friendly

Families Welcome at the Post-Frame Builder Show, York, Pennsylvania

■ By Missy Beyer, Event Director

Once again, this June, Pennsylvania becomes a hub for builders, suppliers, and industry professionals as the Post-Frame Builder Show [postframebuildershow.com] takes over the York Expo Center. While this event is rooted in business-to-business networking and education within the post-frame, rural and plain construction industries, it has also gained recognition for its welcoming, family-friendly atmosphere—a feature that sets it apart from standard trade shows.

At its core, the Post-Frame Builder Show is designed to help professionals connect with exhibitors, discover new products, and gain insights through informational sessions. Exhibitors travel from across the country to showcase the latest in materials, tools, and building solutions tailored to post-frame and other types of rural construction businesses. The event's schedule includes dedicated informational sessions and exhibit hours on June 10 and 11, 2026, providing attendees with focused time to do business while still leaving room in their calendars for personal experiences and family time.

What truly distinguishes this event is the commitment to making it a comfortable and inclusive experience for attendees who bring along family members. Recognizing that many trade professionals balance business with family life, the show integrates elements that help make the visit enjoyable for all ages—without distracting from its professional purpose.

One of the most talked-about features is the Rest Stop, located right in the mix of things within the exhibit hall. This thoughtful space offers an oasis amid the



There's always a place for families at the Post-Frame Builder Show. SHIELD WALL MEDIA PHOTOS.

bustling show floor, where families can take a breather. Parents can sit down with their children, relax, recharge phones or devices, and regroup before heading back into the exhibits. The Rest Stop provides a much-needed break for younger visitors who might otherwise find the exhibit hall overwhelming or tiring.

This oasis isn't just a kid friendly zone with games, it's a comfortable, dedicated space designed with families in mind. Its presence sends a strong message: while the Post-Frame Builder Show is focused on business, it respects the needs of attendees who travel with spouses, children, or companions. It's a place to pause, share a snack, check out local travel guides, or simply enjoy a quieter moment away from conversations about suppliers and specifications.

In addition to the dedicated family space, the overall atmosphere of the venue during the event is warm and collegial. Attendees often comment on the friendly interactions not just among professionals but with those who accompany them. Exhibitors know that families might explore booths together during slower show times, and many are happy to engage respectfully and inclusively with non-industry visitors.



This family-friendly approach reflects a broader trend in professional events: making trade shows not just about deals and demos, but about community. For many visitors, the Post-Frame Builder Show becomes more than a business stop—it's part of a summer trip, an opportunity to enjoy York's historic downtown, and a shared experience that combines work and family time.

Whether you're a seasoned builder or new to the industry, bringing along family to the Post-Frame Builder Show can turn a productive business visit into an enjoyable experience for everyone—thanks in part to thoughtful touches like the Rest Stop. **FBN**

Designing Insulation for Steel-Clad Post-Frame Buildings

As a pole barn (post frame) building neophyte four decades ago, almost all buildings were designed for cold storage, rarely was insulation or potential climate control even a topic for discussion. In today's post frame world, most buildings will need or must have some degree of climate control.

Potential post frame building owners often overlook proper insulation planning for several reasons. Post frame building providers and builders (lumped together as providers for sake of brevity to follow) more-often-than-not play into this.

Focus on Structural Aspects: Providers often prioritize building's structural integrity and aesthetics over energy

efficiency. Insulation, while crucial, may be seen as a secondary concern.

Lack of Awareness: Many owners may not fully understand insulation's importance in maintaining energy efficiency and comfort. Insulation is often seen as an afterthought rather than a critical building process component. Some providers may not be fully aware of latest insulation technologies and their benefits, leading to insufficient recommendations for energy-efficient solutions.

Cost Considerations: Insulation can add to initial construction costs. Some owners may prioritize immediate savings over long-term benefits, leading them to skimp on insulation. Providers are often selling on low price, rather than

best design solutions for their clients. Discussing insulation can lead to higher initial costs, causing some to avoid to keep projects within a perceived budget. They may fear emphasizing insulation needs could deter clients. Keep in mind, there is always someone willing to cut quality and/or service for a lower price.

Complexity of Installation: Insulating a post frame building can be perceived as a complicated task. Owners might feel overwhelmed by technical aspects, such as selecting right insulation types and ensuring proper installation techniques.

Focus on Aesthetics: Designing a new building is exciting, owners may prioritize visual appeal and layout over functional elements like insulation. After all, it is not



COURTESY OF TROYER POST BUILDINGS

visible once the building is completed.

Client Knowledge Gap: Many clients may not understand insulation's importance, so providers might assume it's not a priority for them. This can result in a lack of proactive communication about insulation options.

Misunderstanding Building Codes: Some may not be fully aware of local building codes dictating insulation requirements, leading to inadequate planning. Plus, building codes regarding insulation can vary significantly by location. Providers might not emphasize insulation if local codes do not mandate specific R-values or insulation types.

Procrastination: There can be a tendency to delay insulation planning, thinking it can be addressed later. This procrastination can lead to higher energy bills and long run discomfort.

Unlike stick frame construction, post frame buildings can be very efficient in reducing thermal bridging. By utilizing 2x8 bookshelf wall girts 24 inches on center on a 3 ply Glulam column, less than 6% of a given wall has a wood member touching both exterior and interior surfaces, under half of typical stick frame!

Importance of Insulation

Proper insulation in a post-frame building serves several purposes:

▫ **Energy Efficiency:** Insulation minimizes heat loss in winter and heat gain in summer, reducing reliance on heating and cooling systems.

▫ **Moisture Control:** Effective insulation helps prevent condensation. If overlooked condensation can lead to mold, rust, and structural damage. Insulation helps maintain a consistent indoor temperature, preventing warm, moist air from coming into contact with cold surfaces where condensation typically forms. This is particularly important in winter when temperature difference is significant.

▫ **Comfort:** A well-insulated building maintains a stable indoor temperature, enhancing comfort for occupants.

▫ **Noise Reduction:** Insulation can also

dampen sound, making interiors quieter.

Types of Insulation

When selecting insulation for a steel-covered post-frame building, consider the following options:

▫ **Fiberglass Batts:** A common choice due to its cost-effectiveness and ease of installation. It is available in various R-values, measuring thermal resistance. Generally, fiberglass insulation is fairly affordable, making it a popular choice for budget-conscious projects.

▫ **Mineral Wool Batts:** Offer a higher R-value than fiberglass, typically around R-30 for a 7.25-inch thickness, meaning better thermal resistance (roughly 50% greater than fiberglass). Naturally repels water and resists mold growth. Has a slight edge in sound absorption over fiberglass due to its density.

▫ **Closed Cell Spray Foam Insulation:**

Offers superior air sealing and higher R-values per inch compared to fiberglass or mineral wool. It expands to fill gaps, providing excellent moisture control.

▫ **Blown-In Insulation:** Ideal for attics and hard-to-reach areas, blown-in fiberglass, granulated mineral wool or cellulose can create a thick thermal blanket. If moisture is introduced to cellulose, it can create an environment conducive to corrosion of steel panels. This is due to certain hygroscopic fire retardants exacerbating this issue by retaining moisture against steel.

▫ **Rigid Foam Board:** Provides a high R-value and can be used on walls and ceilings. It is particularly effective as a continuous insulation layer, however should not be placed over framing and directly under steel cladding as shear strength of steel will be greatly reduced or entirely negated.



RIGIDPLY RAFTERS
 MANUFACTURERS of LAMINATED TIMBERS and WOOD TRUSSES
RIGIDPLY.COM
 717.866.6581

Determining R-Value Requirements

R-value needed for insulation depends on climate zone and intended building use. Building Codes provide guidelines for recommended R-values based on geographic location. For Residential structures, see IRC Chapter 11. For other structures refer to International Energy Conservation Code requirements.

So What to Do?

These are broad recommendations based upon my experience.

In Climate Zones 0 through 2:

Closed cell spray foam applied directly to interior face of steel roofing and siding. This will necessitate having to mechanically dehumidify interior spaces.

From Dr. Richard “Rick” Duncan, P.E. Technical Director for the Spray Polyurethane Foam Alliance (SPFA), “Closed-cell naturally shrinks as it cools and cures. It can take about a month for the gases in the cells to come to pressure equilibrium with the atmosphere. When applying SPF to large open areas of metal panels, the shrinkage of the foam can cause some panels to pull inward. We call



COURTESY OF TROYER POST BUILDINGS

this oil canning.

Oil canning occurs most frequently on large unsupported panels (about 4'x4' and larger areas) and on thin gage panels with small ribs. For these large, thin panel areas, use picture framing and apply a thin flash coat to minimize oil canning... especially on ground-level walls where oil canning can be easily seen.

One of the concerns that the metal building industry had was exothermic temperature damage to coatings and primers used on metal panels. A few of the metal panel manufacturers were voiding their warranties because of this concern.



COURTESY OF TROYER POST BUILDINGS

Our study measured exothermic temperatures of the panel during spraying and the temperatures were below 150°F, which should not affect these coatings.

Our study also looked at using different fabrics applied during construction between the sheet metal panels and the framing. We included Tyvek WRB and non-woven ‘BIBS’ fabric. We found that SPF does not adhere well to the more expensive Tyvek. It does adhere to the lower-cost non-woven. We did see that the foam would pull the non-woven fabric away from the panel by

about ½” and eliminates oil-canning. The difficulty with using non-woven fabric is that it must be applied during construction.”

From MCA (Metal Construction Association)’s technical bulletin “Spray Polyurethane Foam Insulation on Interior Surfaces of Metal Panels”:

“Closed-cell foam is recommended due to its water resistant capabilities. Some SPF contractors use a release material such as building wrap or fabric to allow for easier change out of damaged panels, however the use of a release material poses the potential of creating air gaps between the back of the SPF foam and the metal panel. These gaps could allow condensation to accumulate between the SPF and the panel and framing members.”

In other climate zones:

Minimum R-5 (R-10 being both recommended and preferred) insulation shall be provided under full slab area of a heated slab in addition to required slab edge insulation R-value for slabs as indicated in 2021 International Energy Conservation Code (IECC) Table R402.1.2 Footnote (d). Slab edge R-10 insulation is required in Climate zones 3 and greater, with depths of 24” for zone 3, 48” for zones 4 and greater.

Next two paragraphs are paraphrased from Building Science Corporation’s Joe Lstiburek in BSI-059:

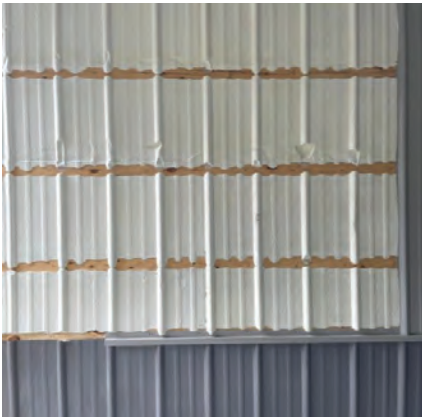

If damaged, steel panels can be pulled off directly applied closed cell spray foam. PHOTO COURTESY OF MIKE MOMB

Do you really need to insulate vertically if you insulate slab edge and insulate under slab at perimeter? Yes and no. Yes in climate zones 4 and higher, no in climate zones 3 and lower. Is this based on a hygrothermal analysis? No. Is this based on an energy payback analysis? No. Is this based on minimizing your carbon “footprint”? No. Get serious. It is based on something real. We found in climate zones 4 and higher if you didn’t do it people felt uncomfortable. It is not a good idea to annoy your clients. Especially if they are old – remember you will get old too – sooner than you expect.

How far inboard should you insulate horizontally? We pick four feet. Yup, this typical rigid insulation sheet width and we go with it. Everywhere? Pretty much. Is there ever any reason to insulate entire slab besides perimeter? Yes, Grasshopper, whenever you have in-slab heating or whenever you have hot-humid summers like you have in Maine, Massachusetts, and Michigan. Those “M” states are a pain. Ground under a slab is still often cold in summer when it finally gets nice outside in “M” states and slab top can fall below outside air-vapor mixture dew temperature when folks are finally brave enough to open windows and doors.

Walls (from out to in): Steel siding, Omnidirectional Housewrap meeting ASTM E2273 drainage efficiency requirements, 2x8 Bookshelf wall girts

blocked solid to 3-ply Glulamated columns, R-30 mineral wool batts, vapor barrier on warm side of insulation to prevent moisture from entering building (this is crucial in climates with significant temperature differences between indoor and outdoor environments), interior finish.

Roof/ceiling (from out to in): Roof steel with factory applied Integral Condensation Control, Vented Eaves and Ridge, raised heel trusses (at least an inch taller than thickness of insulation blown in over finished ceiling).

According to Joe Lstiburek, “Plastic vapor barriers should only be installed in vented attics in climates with more than 8,000 heating degree days.”

Don’t Ignore Air Leaks: Seal any gaps or cracks in building envelope to enhance insulation effectiveness.

Insulating a steel-covered post-frame building is a vital investment paying off in energy savings, comfort, and longevity. By carefully selecting insulation materials, ensuring proper installation, and maintaining moisture control, a comfortable and efficient space can be created to meet user needs for years to come. **FBN**

Mike Momb has been Technical Director for Hansen Pole Buildings, LLC of Browns Valley, Minnesota for more than 20 years. His daily post-frame blog, as well as his weekly

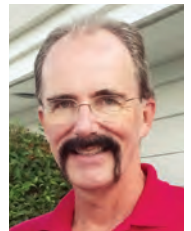

“Ask the Pole Barn Guru” column can be followed at the company website, www.hansenpolebuildings.com/blog/.



We install and service the doors after the sale

Unique Solutions

A classic post-frame appearance while enjoying modern conveniences

Find and contact your local representative here:
<https://powerliftdoors.com/our-locations/>



(844) 275-9351
www.powerliftdoors.com

BY DAVID R. BOHNHOFF, PH.D., P.E.
UNIVERSITY OF WISCONSIN-MADISON

Concrete piers:

Making post-frame buildings greener

JANUARY 2006 FLASHBACK

Two decades have passed since this article first appeared in *Frame Building News*, yet the questions it addresses are more relevant than ever. Post-frame construction has continued to evolve, and builders today still face many of the same considerations surrounding durability, material availability, environmental impact, and long-term performance. Rising concerns about treated-wood preservatives, increasing interest in resilient foundation systems, and a growing focus on sustainability all make this a perfect moment to revisit the insights originally presented.

What readers will find in the following pages is a clear and practical explanation of why concrete piers remain an important option in modern post-frame design. The advantages discussed speak directly to challenges builders continue to navigate. Whether you're comparing foundation systems for cost, performance, or ease of construction, this reprinted article offers a thorough, engineering-based look at concrete piers that still applies to the projects you're building today.

In short, this is a reminder that some foundational principles—literally—stand the test of time.

In recent years, there has been increased interest in constructing post-frame buildings that feature wood posts attached to embedded concrete piers. This interest has been largely spurred by the marketing and fabrication of buildings featuring concrete piers sold under the trade name of Perma-Column (figure

1). Although Perma-Columns are precast products, concrete piers also can be cast-in-place as was done during the 2001 construction of the post-frame building we used to conduct diaphragm action studies in Lester Prairie, Minn. (figure 2).

While slightly more costly than embedded wood post foundations, concrete piers offer many advantages over embedded wood posts and slab-on-grade foundations that builders may not have considered. After reading the following information on concrete piers and the sidebar that follows, it will be apparent that use of concrete piers decreases the environmental impact of post-frame buildings, thus making a green building system even greener.

Advantage of concrete piers over embedded wood posts

When it comes to concrete piers, the question foremost in a builder's mind is why substitute concrete for a preservative-treated wood post when it is generally more difficult and costly to transport and install concrete components, and to attach other components to concrete? In answer to this question, I offer the following seven, largely-interrelated reasons.

1. Durability. Many end users have more confidence in the long-term durability of a concrete foundation than they do in a preservative-treated wood foundation. This is largely due to the poor performance of many solid-sawn posts that were not adequately preservative-treated for ground contact. It is important to note that to date, I am unaware of any documented failures of mechanically-laminated wood posts that have been properly CCA-treated for ground contact.

2. Reduced availability and/or higher cost of CCA-treated lumber. CCA is composed of the oxides of chromium, copper,



FIGURE 1



FIGURE 2

and arsenic. Stating that arsenic is a known human carcinogen and that it is in the public's best interest to reduce levels of potential exposure to arsenic, the Environmental Protection Agency banned manufacturers from treating wood with CCA for most residential uses effective December 31, 2003 (EPA, 2005). While posts for agricultural and commercial buildings can still be CCA-treated, the partial ban on CCA significantly reduces the amount of wood that is CCA-treated, making it more difficult and expensive to obtain.

3. Corrosiveness of CCA alternatives. Alternative treatments to CCA include Alkaline Copper Quat and Copper Azole. Like CCA, these alternative treatments rely on copper toxicity for effective protection

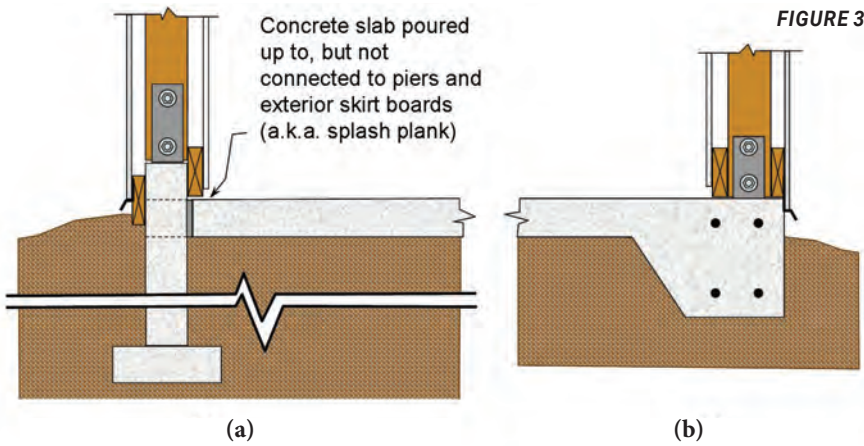

from decay organisms. Unlike CCA, they are not time-tested and tend to leach more copper (Lebow, 2004; Townsend et al., 2003). The greater availability of dissolved copper in these alternative treatments

results in increased galvanic corrosion when metals less noble than copper (e.g., magnesium, zinc, iron, steel, aluminum) are driven into or brought into direct surface contact with the treated wood.

4. Reduced use of preservative-treated lumber. Where possible, engineers try to eliminate preservative-treated lumber because it costs more than non-treated lumber, it generally requires use of more expensive, less-corrosive fasteners, and preservative wood treatments are pesticides which can make eventual disposal of preservative-treated wood problematic (Wilson, 1997). The cost of preservative treatment alone will drive engineers to use posts featuring treated wood spliced to untreated wood in an effort to save money for posts not requiring above ground treatment. Use of concrete piers in this situation eliminates the treated wood altogether, as well as the additional assembly costs associated with joining treated to untreated dimension lumber.

5. Lumber length. Lumber becomes increasingly expensive (on a board foot basis)

GRABER POST BUILDINGS INC.

2026 NFBA CONFERENCE & EXPO BOOTH # 333

WE KNOW POST-FRAME

Our team combines outstanding customer service with real job-site know-how, ensuring you get exactly what you need for your roofing or building project.

We offer top-tier products at competitive prices, partnering only with the best from steel mills to fasteners.

With our own fleet and piggyback forklifts, we deliver on time whether to your yard or directly to the job site.

Metal Panels • Nail-Lam Columns • Windows/Doors • Coil Sales
Trim Components • Custom Wood Trusses • Full Job Pack Delivery



www.graberpost.com

800-264-5013

in longer lengths. Additionally, dimension lumber is not readily available in lengths longer than 20 feet. When concrete piers are used, the overall length of the wood post is generally shortened by 4 to 7 feet. This means engineers are using shorter, less expensive lumber to obtain the same building heights, and also can build structures with 20-foot eave heights using unspliced sidewall posts.

6. Ease of building disassembly. Agricultural and commercial buildings have a relatively short functional design life. It is therefore beneficial to be able to easily disassemble building components for use in a more functional structure. This is much easier to accomplish when wood posts are attached to concrete piers.

7. Recycling. Reuse of lumber treated with a particular preservative is largely dictated by restrictions placed on its use after it has been on the market for several years. For example, it is not possible to reuse lumber treated with pentachlorophenol in buildings because of restrictions placed on its use in 1984. Some researchers have suggested that the development of good organic-based preservative wood treatments may result in restricted use of all heavy-metal based preservatives, making products treated with CCA, ACQ, and ACC of little value in the future. If this is the case, anything that can be done to replace preservative-treated wood with untreated wood may increase future value of a building.

Advantage of concrete piers over slab-on-grade foundations

When an owner requests a post-frame building with a concrete floor, the builder generally has two options: erect the building with an embedded post/pier foundation system and then install the concrete floor as shown in figure 3a, or place the concrete floor first and then attach the wood posts to the concrete surface. When posts are placed on top of the slab, the slab edge must be thickened and reinforced with steel to handle transfer of post loads and to facilitate post attachment (figure 3b). Since this thickened and reinforced edge functions like a beam in distributing loads to the soil, it is referred to as a grade beam, and the entire slab becomes a slab-on-grade foundation.

When selecting between concrete pier and slab-on-grade foundation systems, the following four advantages of concrete piers should be considered.

1. Total concrete cost. Based on typical grade beam and pier dimensions, the amount of concrete required to add a grade beam around a slab will generally exceed the total amount required for concrete piers. This is especially true with larger post spacings (e.g., 8, 10, and 12 feet) which translate into fewer building piers and less required concrete.

2. Construction flexibility. With concrete piers, the interior slab is placed after the building shell has been erected. This has two major advantages. First, concrete is much more likely to be protected during placement from wind, precipitation in all forms, and temperature extremes. This can translate into fewer unexpected scheduling delays, less need for costly heat and moisture protection

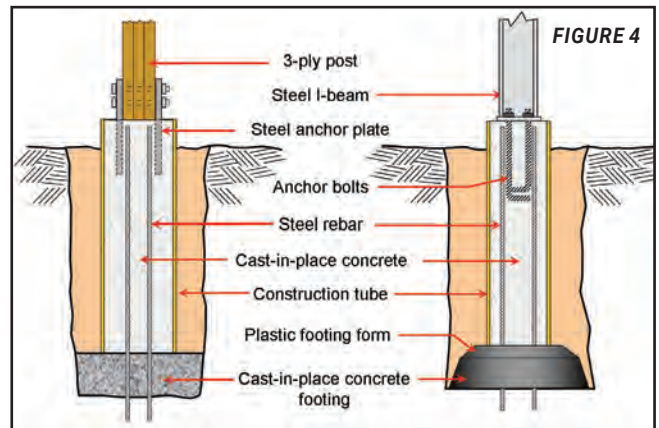

systems, and enhanced concrete surface finish, durability, and strength properties. Second, less preplanning is required for below slab installation of HVAC, plumbing and electrical system components. In fact, no preplanning is required when the interior concrete slab is placed after HVAC, plumbing and electrical system installations have been completed.

3. Structural integrity. The probability of a foundation failure on an expansive clay soil is greatest for a stiffened slab-on-grade (a slab with a reinforced perimeter grade beam) and least for a building completely supported on piers (Green, 2005). Likewise, a building supported on concrete piers is much less likely to be plagued with frost heave problems than is a stiffened slab-on-grade.

4. Foundation reuse. Using a rather simple tripod and hydraulic cylinder, concrete piers can be withdrawn from the soil and reused in another building at a completely different location. Practically speaking, the only way to reuse a grade beam foundation is to rebuild on top of it.

Concrete pier design

Concrete pier design begins with a structural analysis that provides the shear force, axial force, and bending moment at the top of the piers. These forces are largely influenced by the bending (i.e., rotational) stiffness of the concrete pier-to-wood post connection. Most steel brackets used by the post-frame industry to attach wood posts to cast-in-place concrete are treated as pin connections in design because of the lack of bending stiffness of the steel bracket-to-concrete connection, the steel bracket-to-wood post connection, and/or the steel bracket itself. When concrete-to-wood post connections lack bending stiffness, the building designer must rely upon diaphragm action and/or on rigid column-to-truss connections to help handle horizontal components of applied structural loads. Note that the concrete pier-to-wood post connections of the Lester Prairie test building (figure 2) were purposely designed to behave as pins so that diaphragm action could be more effectively evaluated.

Once design loads for a concrete pier have been determined, the pier cross-sectional dimensions and the amount and location of

FIGURE 5



steel reinforcing can be determined in accordance with ACI 318 *Building Code Requirements for Structural Concrete* (ACI, 2005). Calculation of embedment depth can be done in accordance with ANSI/ASABE Engineering Practice (EP) 486.1 *Shallow Post Foundation Design* (ASABE, 2005). Although the EP was largely developed for embedded wood posts, the practice also applies to other embedded post materials. EP Section 3.1.1, which defines “post,” specifically states that “Posts include members of any material with assigned structural properties such as solid or laminated wood, steel, or concrete.” The fact that the EP applies to concrete piers makes sense since soil will not react differently to

Tube diameter (inches)	Tube volume (cubic yards per foot)	Concrete cost, dollars per foot		
		70	80	90
8	.013	.90	1.03	1.16
12	.029	2.04	2.33	2.62
16	.052	3.62	4.14	4.65
20	.081	5.66	6.46	7.27
24	.116	8.14	9.31	10.47
28	.158	11.09	12.67	14.25
32	.207	14.48	16.55	18.62
36	.262	18.33	20.94	23.56

posts/piers of similar shape, size and flexural stiffness.

Cast-in-place concrete piers



Examples of cast-in-place concrete piers are shown in figures 4a and 4b. These figures show respectively, a concrete pier poured separately of, and simultaneously with, a concrete footing.

Cast-in-place piers are typically formed with single-use, spirally-wound paper tubes. These forms are frequently referred



BUILD THE EXCEPTIONAL WITH QUALITY DOORS & WINDOWS

By A.J. Manufacturing

Your Source for Post Frame Doors and Windows.



Building Ideas

800.328.9448 @ www.ajdoor.com



Manufacturer Of Roll Forming Equipment

OUR PRODUCTS

- | | | | |
|---------------|----------|------------|----------|
| Panel Lines | Shears | Wrappers | Custom |
| Trim Machines | Slitters | J-Channel | Machines |
| Uncoilers | Corners | Ridge Caps | |



Order Machine Based On Your Needs



Full-Service Shipping & Installation Available



Customer Support



Versatile Growth Options



Come us at FBE Booth 834



Gold Key of Excellence Award Winner



10850 County Road 320
Millersburg, OH 44654

P: (330) 674-4403
F: (330) 674-4035

wayne@acu-form.com
acuformequipment.com

to as concrete forming tubes, concrete construction tubes, or by a manufacturer's trademarked name (Sonotube, Smurfit, Essex Tubes, Formatube, Opt-T-Tube, Quiktube, Crescent Tube). Tubes up to 4 feet in diameter and 20 feet long are available. Nominally 8- and 12-inch diameter tubes are generally stocked locally and retail for approximately \$1.50/foot and \$2/foot, respectively. Note that several tubes are nested for shipping (i.e., tubes are slid inside other tubes), and thus are available in a variety of diameters close to the nominal size.

Simultaneously pouring piers and footings saves considerable time and is facilitated with special isolated footing forms. Three companies currently manufacture and market such forms as shown in Figure 5. The first patented was TubeBase produced by Sound Footings LLC which is owned by DEW Construction Corp. of Williston, Vermont (Wells, 1987). Ten years later the Bigfoot Systems Footing Form produced by F&S Manufacturing Inc., Martins Point, Nova Scotia (Swinimer, 1998) and the Redibase Forming System by Redibase Inc., Fulford, Quebec (Croghan, 1998) were patented. Suggested retail prices for a 24-inch TubeBase, Bigfoot Systems Footing Form, and Redibase Forming System are \$18, \$21, and \$11, respectively. Construction tubes are attached to the Redibase Forming System with duct tape, and to the TubeBase and Bigfoot Systems Footing Forms with screws.

Figure 6 shows another forming system for cast-in-place piers — the one-piece Footing Tube patented and sold by Brent Cliff of Fredericton, New Brunswick (Cliff, 2001). Three different Footing Tube sizes are available: a 6-inch deck tube, an 8-inch footing tube, and a 10/12-inch footing tube. The 6-inch deck tube has an overall length of 54 inches, top diameter of 6 inches, and inside base diameter of 14 inches. The 8-inch footing tube is 62 inches long with an 8-inch top diameter and 22-inch inside base diameter. The 10/12-inch footing tube has a 2-inch top ring that is 10 inches in diameter. When this top ring is cut off,

the remaining tube is 62 inches long with a 12-inch top diameter and 22-inch inside base diameter. The 6-inch deck and 8- and 10/12-inch footing tubes hold 2.3 feet³, 4.8 feet³ and 8.5 feet³ of concrete, respectively, and have a manufacturer's suggested retail price of \$35, \$41.50, and \$46, respectively.

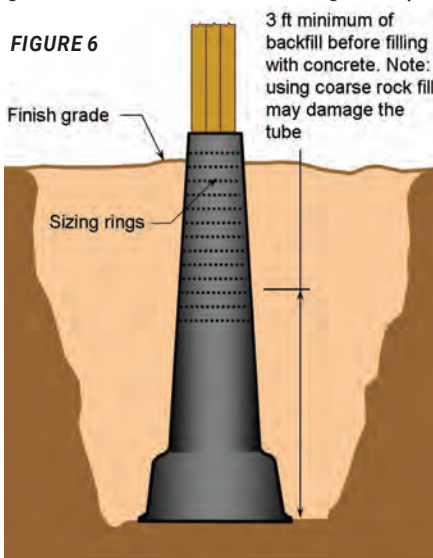

A cast-in-place alternative to the piers shown in figures 4 and 6 is to auger a hole equal in width to the required footing diameter, and then fill it with concrete. Although this eliminates much of the formwork, the resulting soil-concrete interface makes it more susceptible to frost heave, and such piers can end up costing more than systems featuring special forms. For example, at \$80 per cubic yard, total concrete cost is around \$47 for a 5-foot long pier that is poured into a hole with an effective average diameter of 24 inches (see Table 1). Replacing this with a system utilizing a 12-inch diameter construction tube and 24-inch diameter Redibase Forming System (the base holds 1.65 feet³ of concrete) cost slightly less than \$34. The cost advantage of using footing forms (over pouring directly into an augered hole) increases with increases in hole depth, required footing diameter and/or concrete cost.

There are many different ways to attach a post/column to a concrete pier. One option for wood posts is to attach them to

steel bars cast vertically in the pier (figure 4a). A more conventional option is to rely on anchor bolts cast in the concrete (figure 4b) or drilled into the concrete (figure 2). Alternatively, a steel column can be welded to a horizontal steel plate that has been cast into the top of the pier.

Precast concrete piers

A precast concrete pier is any pier that has been cast in a location other than its final location. Consequently, a pier fabricated on-site would be considered a precast pier if it is moved into a posthole after significant curing has taken place.

As previously noted, recent interest in concrete piers is largely due to construction of numerous post-frame buildings with Perma-Columns (figure 1) — a rectangular precast concrete pier developed and patented by Perma Column Inc. of Ossian, Ind. (Meyer and Stoller, 2005). The schematic in figure 7 shows the four continuous steel reinforcing bars which are part of every Perma-Column. Figure 8 shows the five different sized piers the company currently produces at each of its four U.S. manufacturing locations. Typical pricing for the PC6300, PC6400, PC8300, and PC8400 are \$59, \$68, \$85, and \$89, respectively. Note that Perma-Columns are a little bit wider but equal in width to the wood post/column they support. Engineering design properties for the concrete base and steel connector are available from www.perma-column.com.

Precast vs. cast-in-place

Precasting of piers would appear to have the following advantages over casting piers in-place.

1. Concrete quality. Precasting is almost always done in a dedicated batching plant where it is easier to control concrete ingredients and the conditions under which the ingredients are mixed and then consolidated into forms. Placement of reinforcing is also more easily monitored in a plant setting, and concrete can be ideally cured in special humidified chambers.

2. Handling fresh concrete. Precasting

eliminates handling of ready-mix concrete on the jobsite. This eliminates the need for concrete placement tools and the water needed to clean them. It should be noted that concrete pier placement requires few tools (and hence cleaning water) if the concrete ready-mix delivery truck can directly place concrete in all formwork.

3. Construction delays. Workers must wait for cast-in-place concrete piers to cure before proceeding with building shell assembly. Additionally, adverse weather conditions can delay concrete placement. On occasion, field personnel are left waiting for concrete delivery because they have finished their forming and other preparation work well before scheduled delivery and have nothing left to do, and/or the delivery is late.

4. Post preassembly. Irregardless of the type of pier used, the wood post/column must be attached to the pier at some point. In the case of precast piers, this attachment can be made before piers are inserted into post holes (i.e., the entire post can be preassembled). This results in a post installation that is essentially no different than that for an all-wood assembly. Manufacturers often opt to do this preassembly in the factory where adverse weather is never a factor and special fixtures can be utilized to obtain

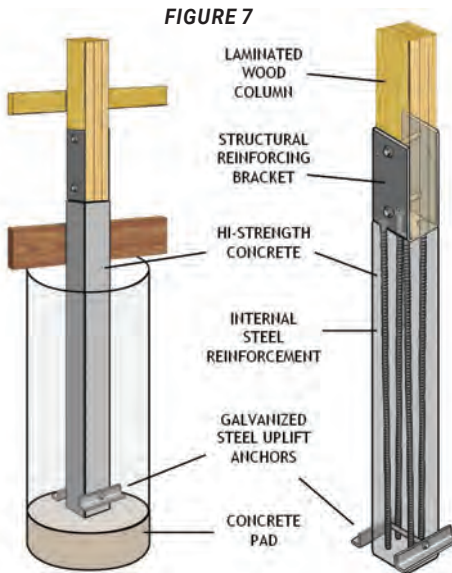

FIGURE 7

quick and accurate assembly.

5. On-site labor. Installation of cast-in-place piers requires that concrete forms and steel reinforcing be carefully installed and fixtured in place, and that elevation of pier tops be established prior to concrete placement. More difficult and time-consuming is the fixturing of any post/column anchors that are to be installed in the fresh concrete. For this reason, designers may opt to drill-in anchors after concrete has cured. Drilling-in anchors also takes time, and using

them places more restrictions on design since it is very difficult to achieve much of a moment resisting connection with them.

Cast-in-place piers would appear to have the following advantages over precast piers.

1. Uniformity of contact. Cast-in-place concrete conforms to soil and whatever else it is cast against. This translates into good, uniform contact between soil and footing, and between footing and pier in situations where they are poured separately. Conversely, precast piers are typically used with precast footings, and good uniform contact between a precast footing and the soil requires that the soil surface be flat prior to footing placement. Additionally, if the precast footing is not level, the precast pier will only make line or point contact with the footing. Obtaining a flat and level surface for precast footing placement is much easier with the use of a posthole bottom leveler (Bohnhoff, 2005).

2. Height Adjustment. The top elevation of cast-in-place piers is controlled by striking off the surface to its desired height during concrete placement. The top elevation of a fixed-length precast pier can only be controlled by controlling footing elevation. The latter is not difficult, but adds slightly to the time required to place

ATLAS
BUILDING PRODUCTS

ASHLAND, OH
(800) 321-6977

FLAT ROCK, NC
(828) 629-2603

HOUSTON, TX
(800) 503-2105

FLAT TOP®

- HIGHER HEX PROVIDES POSITIVE SOCKET ENGAGEMENT
- SPECIAL UNDERCUT DESIGN ENTRAPS SEALING WASHER

#10 ULTIMATE®

- ZINC CAST HEAD WARRANTED AGAINST RED RUST FOR THE LIFE OF THE BUILDING
- SPECIAL UNDERCUT DESIGN CONCEALS WASHER

2026
NFBA
CONFERENCE & EXPO
BOOTH #
543

ATLASFASSTENERS.COM

USA MANUFACTURING & DISTRIBUTION TO SUPPORT YOUR BUILDING PRODUCT NEEDS

footings. During recent construction of a post-frame building, I used a posthole bottom leveler with an attached laser level receiver to level the bottom of postholes to a predetermined elevation. I then compacted the soil, installed the precast footings, and used the laser level to measure the installed depth of each footing. These measurements revealed a standard deviation on final elevation of only 0.35 inches.

The ultimate choice as to whether to use precast or cast-in-place concrete piers will typically come down to overall cost. There is typically less uncertainty in the pricing of precast pier systems since there are fewer unknowns relating to on-site installation. Each system requires the storage, handling and transportation to the jobsite of components (precast piers in one case; formwork, steel reinforcing, and anchors in the other). On-site labor is measurably greater for cast-in-place piers. Cost for site delivered concrete will depend on location and quantity needed. Note that the typical pier does not require that much concrete, and thus for smaller buildings you will generally be required to pay an additional delivery fee.

FIGURE 8

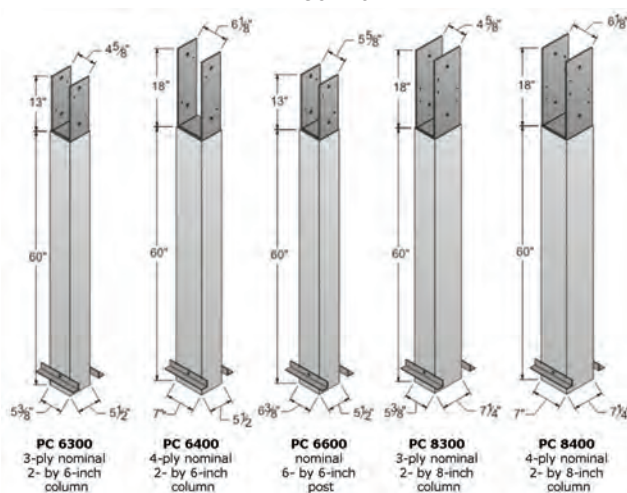

Conclusions

Although concrete piers may be more expensive than embedded wood post foundations, they have advantages over their embedded wood counterparts, and these advantages become increasingly important with time. Based on total cost, construction flexibility, structural integrity, and component reuse, a concrete pier foundation system with an isolated concrete slab would appear to be a better option than a slab-on-grade foundation system. Design of precast and cast-in-place concrete piers is a very straightforward process that can be accomplished using common engineering design specifications and procedures.

Construction of cast-in-place piers has been enhanced by the broad availability of round, cardboard forming tubes, and the manufacture of special isolated footing forms which attach directly to cardboard tubes. These isolated footing forms enable quick fabrication of a concrete post with a bell-shaped bottom for increased bearing capacity and uplift resistance. Precast piers have several

advantages over cast-in-place concrete piers. It is important to account for these factors during any economic/feasibility analysis comparing the two systems. **FBN**

References

- ACI. 2005. ACI 318-05: Building code requirements for structural concrete and commentary. American Concrete Institute, Farmington Hills, MI. (<http://www.concrete.org/>)
- ASABE. 2005. ANSI/ASAE P486.1 Shallow post foundation design. In the 52nd edition of ASAE Standards. American Society of Agricultural and Biological Engineers. St. Joseph, Mich. (<http://www.asabe.org/>)
- Bohnhoff, D. R. 2005. Post Installation Tools. Presented at the 2005 ASAE Annual International Meeting, Tampa, FL. ASAE Paper No. 054119 ASABE, St. Joseph, MI.
- Cliff, B. 2001. Anti-frost concrete mould. U.S. Patent 6,318,700. November 20, 2001. Available at: <http://www.uspto.gov/patft/index.html>.
- Croghan, M.T. 1998. Base mold for concrete post. U.S. Patent 5,800,727. September 1, 1998. Available at: <http://www.uspto.gov/patft/index.html>.
- Green, E.C. 2005. Excessive movement: Risk management and the design of foundations on expansive clay soil. Structural Engineer, October, 2005. pp. 34-37.
- Lebow, S. 1996. Leaching of wood preservative components and their mobility in the environment—Summary of pertinent literature. Gen. Tech. Rep. FPL–GTR–93. Madison, WI: U.S. Department of Agriculture, Forest Service, Forest Products Laboratory. 36 p.
- Lebow, S. 2004. Alternatives to chromated copper arsenate (CCA) for residential construction. In: Proceedings of Environmental Impacts of Preservative-Treated Wood February 8 - 11, 2004; Orlando, Florida, USA. Florida Center for Environmental Solutions Gainesville, Florida; (pre-conference Proceedings) 1 CD-Rom pp 1-12. Available at: http://www.fpl.fs.fed.us/documnts/pdf2004/fpl_2004_lebow002.pdf
- Meyer, R.L. and P.T. Stoller. 2005. Precast concrete column for use in post-frame construction. U.S. Patent 6,964,139. November 15, 2005. Available at: <http://www.uspto.gov/patft/index.html>.
- Swinimer K. 1998. Prefabricated form for molding a footing of a settable structural material. U.S. Patent 5,785,459. July 28, 1998. Available at: <http://www.uspto.gov/patft/index.html>.
- Townsend, T., K. Stook, M. Ward, and H. Solo-Gabriele. 2003. Leaching and toxicity of CCA-treated and alternative-treated wood products. Technical Report #02-4. Florida Center for Solid and Hazardous Waste Management, 2207 NW 13 Street, Suite D, Gainesville, FL 32609. 137 p.
- USEPA. 2005. Chromated Copper Arsenate (CCA): Health and Safety Information. Published on the U.S. Environmental Protection Agency website at: http://www.epa.gov/oppad001/reregistration/cca/health_safety.htm
- Wells, G.T. 1987. Footing form. U.S. Patent 4,673,157. June 16, 1987. Available at: <http://www.uspto.gov/patft/index.html>.
- Wilson, A. 1997. Disposal: The Achilles' Heel of CCA-Treated Wood. Environmental Building News. Volume 6, Number 3, March 1997.



rFOIL THE BEST WAY TO INSULATE METAL ROOFING

CLASS 1/A Fire Rating

888-887-3645
www.rFOIL.com

Manufactured by: **COVERTECH**

FBE SHOW BOOTH #332



Aztec Washer Company

MASTER FLASH[®]
ROOFING • PLUMBING • ELECTRICAL • HVAC • SOLAR

From the smallest to the **LARGEST**,
the most complete line available.

Pipe Range: Fits: 1/8" to 39-1/2" Pipes
Base Range: 2-1/4" to 44" (1 meter)

1-800-WASHER 5 (927-4375) • Ph: 858-513-4350 • info@aztecwasher.com • www.aztecwasher.com



METAL ROOFING FASTENERS

THAT MAKE THE DIFFERENCE

RED DOT PRODUCTS

833-473-3368
465 N Reading Rd,
Ephrata, PA 17522
RedDotProducts.com

FBE SHOW BOOTH #314



Superior Quality Telehandler Boxes

In-Stock For Next Day Shipping

Creekside MANUFACTURING LLC

Call Justin at (717) 355-2008
Email: office@creeksidemfg.com
www.creeksidemfg.com
137 Meadow Creek Road, New Holland, PA 17557

WANT TO SEE ALL OF OUR DUMPSTER PRODUCTS? Ask for our FREE catalog!



Radiant Floor Heat!

- Warm, Silent & Efficient
- Hot Water or Electric
- Tankless Hot Water
- Slabs
- Wood Floors
- Geothermal
- Wood Boilers

935 N. 275 W. Suite B • Angola, IN 46703
See us at www.indianawarmfloors.com
260-668-8836 • 800-700-8830



POLESAVER-PF

The ultimate protection for post frame foundations, backed by a 40-year rot prevention guarantee.

Phone: (610) 377-3270
Polesaver-pf.com

40 YEAR Guarantee

FBE SHOW BOOTH #552



PINE HILL MOVING YOU FORWARD.

THE MATERIAL TRAILER SERIES

MADE FOR THE METAL ROOFING & POLE BARN INDUSTRIES, DELIVERING SUPERIOR RELIABILITY AND PERFORMANCE EVERY TIME. FEATURING REMOTE-CONTROLLED ROLLERS, TILT DECK, AND EXTENSIONS, IT TRANSFORMS UNLOADING INTO A ONE-PERSON OPERATION – NO FORKLIFT REQUIRED.

PINEHILLTRAILERS.COM | (717) 288-2443 | 5140 MARTIN DRIVE, GAP, PA 17527

FBE SHOW BOOTH #846



WEBSITES & ONLINE MARKETING

- ✓ Search Engine Optimization
- ✓ Marketing Strategy
- ✓ Google Ads & Social Media

E-IMPACT marketing

(717) 929-8780 sales@eimpact.marketing

FBE SHOW BOOTH #916

LOOKING TO EXPAND INTO COMMERCIAL ROOFING?

We have the materials & the training to help.



WANTED!

- Roofing Installers (Increase your profits)

HEARTLAND SALES AND MACHINE

Your #1 Roll Forming Support Equipment Source

- Power Panel Wrappers
- Power Trim Wrappers
- Automatic Wrappers
- Coil Tipppers
- Ag Panel Power Shear
- Custom Products

Rochester, IN 46975 (574) 223-6931

PLASTISLEEVE® POST PROTECTION

The "Original" post protector

- Low cost - Easy slide on
- Also available, **PLASTISHIRT** board protector

sales@plastisleeve.com
Toll free 877-775-3383

www.plastisleeve.com

FBE SHOW BOOTH #215

Are You Ready to Get DOMED?

- Rated #1 Best Product for Value & Performance by leading Consumer Report testing organization
- Military grade 6063 extruded and tempered to T5 aluminum support frame
- GutterDome is a highly profitable premium gutter guard solution to an annual homeowner problem

www.GutterDome.com
Call 877.987.4888
FREE Dealer Product Sample Kit

AMERICAN MADE TOUGH FOR STEEL

BECK AMERICA Inc. 800-239-8665 | www.beck-fastening.com
ET&F® is a registered trademark of RAIMUND BECK GMBH.

MAKE YOUR OWN GUTTER GUARD

We manufacture custom gutter guard machines.

- You design it-We build it.
- Send us a drawing of the design you want and we will send you a quote.
- Include your phone number so we can call you back.

REASONABLE PRICING

Flack Hill Machine
7671 State Rte 514 • Big Prairie OH 44611

Distinguish your roofs with Grandura snow guards.

- Unique shapes
- 40+ color options
- Easy installation

Are you a standing seam roofer? Request your free demo kit today!

Order Now! 272.215.7196

Everlast Roofing, Inc.

OUR NAME SAYS IT ALL

PROFILE OPTIONS

EVERLAST II™ | EVERDRAIN™

WHY EVERLAST?
AZM™ with Activate Technology Synergy® Paint System
Cut Edge Corrosion Inhibitor™ (CECI™)
Heat Forming
Most corrosion resistant panel in the industry

AZM ACTIVATE TECHNOLOGY

Lebanon, PA 10 Enterprise Court Lebanon, PA 17042	Howe, IN 7180 N 050 E Howe, IN 46746	Bridgton, ME 24 JF Mains Drive Bridgton, ME 04009	Orwell, OH 161 Grand Valley Ave Orwell, OH 44076
---	--	---	--

FOR MORE INFORMATION CALL: 888.339.0059 OR VISIT US AT WWW.EVERLASTROOFING.COM

FBE SHOW BOOTH #645



Formwright

Outfitting Standing Seam Rollforming Businesses

Machines | Trailers | Tools | Service

Give Us A Call Today • **260.463.4010**



NJM
New Tech Machinery
A MAZDA COMPANY

FBE SHOW BOOTH #414

ASCO machines USA



(217) 955-ASCO

WWW.ASCO-MACHINES.COM



Storage Components & Building Components

DESIGN • MANUFACTURE • QUALITY

www.storageexp.com

Angel Hayes | President

305-586-3033

90 W. Orange St., Juno Park, FL 32025

ahayes@storageexp.com • www.storageexp.com



UNITED STEEL SUPPLY

STEEL PRODUCTS FOR THE METAL ROOFING & METAL BUILDING INDUSTRY

Understanding Superior Service



512-263-0954 • unitedsteelsupply.com

FBE SHOW BOOTH #621

Aluminum Folding Stairs

Heavy duty • Use in garages, shops, pole barns, barns, etc.

Standard rough openings

- 22 1/2 x 105 1/2
- 37 x 105 1/2
- 46 1/2 x 105 1/2

Up to 12'8" ceiling height
Ship anywhere in the U.S.



DALAM WELDING

7655 S 200 W TOPEKA, IN 46571

Call for Dealers near you.
260-593-0168

Premium Quality

ROLLFORMING MACHINERY

PANEL LINES	ROLL UP STATIONS
TRIM ROLLFORMER	TRACK LINES
PURLIN LINES	DECKING LINES
ROLL UP DOOR LINES	COIL UPENDER
SEAMING STATIONS	DOUBLE HEMMER



ASC MACHINE TOOLS, INC.

Made in the USA since 1949!

TEL (509) 534-6600 www.ASCMT.com

FBE SHOW BOOTH #632

WE ADD THE VALUE TO THE METAL



MARION MANUFACTURING



- Automation Systems
- Metal Construction Rollformers
- Coil Processing
- Forming & Fabrication
- Recondition Existing Machines

620-382-3751

www.marionmanufacturing.com

FBE SHOW BOOTH #922

HEAVY-DUTY ANCHOR BRACKETS

Sturdi-Wall® drill set model
Sturdi-Wall® Plus wet set model
ICC-ES certified code compliance

permacolumn.com



PERMA COLUMN.

BUILD BETTER. BUILD STRONGER. BUILD TO LAST.

FBE SHOW BOOTH #415



Golden Rule
FASTENERS
QUALITY PRODUCTS
COMPETITIVE PRICES
& MOST ORDERS SHIP THE SAME DAY

- Screws • Closures • Ridge Vent
- Pipe Flashings • Butyl Tape • And much more!

Ph: (334) 283-4030 - FAX (334) 283-4032
info@goldenrulefastenersinc.com - www.goldenrulefastenersinc.com



SteelGrip SAMP, Inc.
Preventing Injuries and Saving Lives®

SAMP MATS:
Easy to use magnetic grip provides safer footing when working on steel roofing. Get maintenance jobs done faster and easier.

SteelGrip SAMP
Safety Assist Magnetic Mat
231-944-0109
SteelGripSamm.com

MANUFACTURER OF ROLL FORMING EQUIPMENT



- Coil Upenders • Shears • Slit Line • Uncoilers • Trim Roll Formers
- Wrappers • Panel Lines

Acu-Form
ROLL FORMING EQUIPMENT
Millersburg, Ohio
(330) 674-4003 - ACUFORMEQUIPMENT.COM

FBE SHOW BOOTH #834



DIRECT METALS Everything but the coil on one pallet.
Fasteners and Accessories for Rollforming Manufacturers and Wholesale Building Products Distributors.

Accessories and Components for

- Metal Roofing • Standing Seam • Low Slope • BUR • TPO
- Asphalt Shingle Roofing • Post and Steel Frame Buildings

Home of the WoodZip, SteelZip, ConZip, Dekzip, Panclip, and S.C.A.M.P. line of premium fasteners.



www.directmetalsinc.com Phone: 855-800-8878



Green Post™
Planet Saver Industries

THE MOST AFFORDABLE, ALL-IN-ONE SOLUTION FOR IN-GROUND POST DECAY AND UPLIFT RESTRAINT

P (610) 377-3270
www.planetsaverind.com Made in the USA

FBE SHOW BOOTH #550



Darin Westhoff
President
Office: 888-345-2645
Cell: 641-680-3802

Coil Spot **Wildcat Fasteners** **SPEEDLAP**
Happy Jobsites!

3 Brands 1 Mission

FBE SHOW BOOTH #627



SAMCO
People. Products. Passion.

Providing Complete Turnkey Roll Forming Solutions for Over 50 Years

1 416 285 0619
www.samco-machinery.com

POST-FRAME ■ RURAL ■ PLAIN
BUILDER SHOW
June 10-11, 2026
UPMC Arena, York Expo Center, York, PA

FOR MORE INFORMATION CONTACT MISSY BEYER:
missy@shieldwallmedia.com • 715-350-6658
FAX 1-715-227-8680



PHOTO COURTESY OF HD QUALITY BUILDERS, INC.

Post-Frame Garages

Help Clients Achieve a Residential Style

■ By Linda Schmid

Post-frame construction continues to dominate the detached-garage market thanks to its speed, efficiency, and design flexibility. Increasingly, however, clients expect their outbuildings to complement nearby homes rather than stand apart from them. Builders can deliver that look with deliberate attention to form, proportion, and detailing—without sacrificing structural performance or efficiency.

Form and Proportion: Getting the Basics Right

The structure's shape and mass determine its first impression. A tall rectangular box with a shallow roof pitch signals "ag use," while a lower wall height and steeper roof create residential proportions. Roof pitches in the 4/12–6/12 range usually

blend well with neighborhood architecture, and 12–24-inch overhangs establish familiar shadow lines and visual softness.

Breaking up wall planes with wainscot, varying siding orientation, or adding a small bump-out can visually reduce the scale of large façades. Builders can also use porch extensions or dormers to introduce architectural rhythm without compromising structural simplicity.

Coordinate overhang depth and soffit treatment early in design. A 12-inch vented overhang not only improves attic ventilation but also reinforces the visual cues of residential architecture.

Roofs: Matching the Dominant Element

Rooflines dictate the structure's visual identity. For garages adjacent to homes, it's best to match the main house's form—

RESOURCES

- H&D Quality Builders
www.HDQualityBuilders.com
- Wick Building Systems
www.WickBuildings.com

gable, hip, or combination. This approach immediately establishes cohesion.

Concealed-fastener metal panels, such as snap-lock or mechanically seamed standing seam systems, are increasingly accepted in residential zones. These panels provide high wind resistance, a sleek appearance, and longevity. Architectural asphalt shingles can be used to match the home's roof, provided adequate roof decking and high-temperature underlayment are installed. Metal roofing that emulates the look of the home's look may also be available.

Small additions, dormers, cupolas, or decorative gable vents, enhance ventilation while breaking up long ridges and creating residential interest.

Always confirm local design covenants and HOA rules before finalizing roof material or color. Compliance is easier when you present sample photos and finish swatches early.

Siding Systems and Color Strategy

Siding defines the aesthetic language of the structure. While exposed-fastener vertical rib panels remain efficient and economical, they often read “agricultural.” Builders aiming for a residential appearance should consider alternatives such as:

- Horizontal lap panels (steel, vinyl, or fiber cement) for traditional neighborhoods.
- Concealed-fastener board-and-batten steel for modern farmhouse styles.
- Hybrid designs with masonry, stone, or brick wainscot for a grounded visual base.

Color coordination matters. Neutral or earth tones harmonize easily with residential surroundings, while contrasting trim can highlight architectural lines. Matching fascia, soffit, and fasteners in tone gives a cohesive, professionally finished look.

Keep a small “residential palette” on hand – samples of metal and composite finishes that match common home colors. It speeds client approvals and prevents mismatched substitutions.

Openings and Exterior Detailing

Overhead doors and windows are some of the most visible transitions from agricultural to residential styling. Choose carriage-style or paneled overhead doors with decorative hardware, and divided-lite or gridded windows that echo house fenestration.

Trim boards around openings serve both aesthetic and practical functions: they frame the structure visually and conceal flashing details. Matching corner trim and fascia profiles to residential scale helps the building blend.

Exterior lighting, wall-mounted lanterns, soffit downlights, or post-mounted fixtures, can not only look residential but



PHOTO COURTESY OF WALTERS BUILDINGS

also contributes to nighttime curb appeal and occupant safety.

Building Tip: Align window and door headers on a common elevation line for visual order and easier layout during framing.

Structural Coordination and Transitions

When building near a home, proportion and elevation alignment are key. Matching eave height, roof pitch, and trim scale is more critical than duplicating every detail. Builders can save cost by using residential finishes only on the visible elevations—street and approach sides—while cladding less visible walls with standard exposed-fastener panels if preferred.

If a house includes masonry or lap siding, use those textures strategically on the garage’s front elevation or wainscot height. The rest of the shell can remain metal without detracting from visual harmony.

When blending materials, specify tran-

sition flashings carefully. Factory-coated steel trims or prefinished aluminum extrusions protect dissimilar materials from galvanic reaction and staining.

Interior Finish and Performance Expectations

Even when the exterior design drives the project, interior expectations are changing. Many post-frame garages double as workshops, studios, or hobby spaces. Finishing interiors with metal liner panels or painted OSB improves reflectivity, durability, and cleanup ease.

Thermal and acoustic performance are increasingly important to clients. Continuous insulation, vapor barriers, and insulated overhead doors ensure the building performs like a residential structure year-round.

Design Communication and Visualization

Builders who invest in realistic render-



PHOTO COURTESY OF WICK BUILDINGS

ings often find clients make faster and more confident decisions. Renderings showing true siding texture, color, and lighting reduce change orders and miscommunication. For design review boards or HOAs, these visuals can also accelerate approvals.

Encourage clients to provide photos of their home and any nearby buildings. Matching the garage's horizontal lines—such as window sills, wainscot height, or roof ridge—helps integrate it visually into the site.

Presenting Design Mock-Ups

When preparing client presentations or permit submittals:

- Use photorealistic rendering tools to demonstrate lighting and shading.
- Include both daytime and dusk scenes to show illumination effects.
- Overlay the rendered garage onto a site photo for context.
- Label proposed materials and finishes clearly on the drawing.

Such documentation not only improves client confidence but also satisfies increasingly common design-review requirements in suburban jurisdictions.

The Takeaway

Residential aesthetics and post-frame performance are not



PHOTO COURTESY OF POLE BARN'S DIRECT

mutually exclusive. When builders control form, finish, and proportion, the system adapts easily to residential environments. These garages demonstrate that post-frame construction can deliver not just economy and strength but also refined architectural aesthetics. **FBN**

Wick Buildings

Commercial ▪ Residential ▪ Agricultural
Retail ▪ Suburban ▪ Equestrian

WICKBUILDINGS.COM 800-356-9682

HIXWOOD

QUALITY COILS... DELIVERED

Visit us at the
Frame Building Expo booth #538

2025 **RB**
Gold Key of Excellence Award Winner

2025 **MB**
Metal of Honor Winner

Call us for all your slit and blank coil needs!
715-644-0765
HIXWOOD.COM



Simpson Strong-Tie PFUD™ Post Frame Undersaddle Hangers

Simpson Strong-Tie, a leader in engineered structural connectors and building solutions, has launched two PFUD™ undersaddle hangers. The hangers feature a two-sided design so that one hanger supports ceiling joists on each side of a truss instead of requiring a separate face-mounted hanger for each joist. The continuous seat fits snugly under the truss's bottom chord, automatically aligning parts vertically for an easier, faster layout. For single-side applications, installers simply bend and separate the hanger along the perforations to create two face-mounted options.

"PFUD undersaddle hangers are extremely versatile, streamlining installation to reduce connector layout labor costs by half versus using two face-mounted hangers," said Randy Daudet, group product manager for Simpson Strong-Tie. "At the same time, the hangers offer greater reliability and load capacity than toenailed ceiling joists."

The hangers are fully tested and code listed. They're load rated for joist tension forces, so they're ideal with ceiling panels acting as diaphragms or for bottom-chord truss bracing.

Two options are available: The PFUD24 fits one-ply trusses, and the PFUDS24 fits two-ply trusses.

www.strongtie.com

True Metal Supply Inspire Steel Siding

Inspire Steel Siding delivers the warmth of wood with the strength of steel, offering a refined exterior solution. Available in 2 distinct plank sizes (6" & 9" coverage), and a range of solid & woodgrain finishes, Inspire elevates curb appeal while providing lasting durability. Its snap-lock system allows



for a clean installation with a sleek 0.5" reveal — perfect for vertical or horizontal applications to suit your architectural style. Inspire provides versatility and low maintenance of steel for residential spaces, as well as commercial applications.

truemetalsupply.com

Malco Tools Expands C-RHEX® Tool Line

Malco Tools, one of the nation's leading solution developers and manufacturers of high-quality tools for the HVACR and building construction trades, has expanded its C-RHEX® line of cleanable, reversible hex drivers to include new hard-sided case kits, 7-in-1 Flip Bit socket sizes, premium grip handles and GoBlue! hex driver variety pack.

The new hard-sided Install Kits and Service Kits provide compact, high-performance solutions for on-the-go pros.

The Install Kit includes three C-RHEX® sockets, two interchangeable shaft lengths, an insert bit socket and 12 impact-rated bits—all housed in a rugged premium case. The Service Kit features Malco's Premium Grip Handle, 12 bits, an insert bit socket and the pro favorite 7-in-1 Flip Bit.

New 7-in-1 Flip Bit socket combinations include 3/8" & 7/16" and 1/2" & 9/16", giving pros six color-coded, cleanable, reversible socket pairs to choose from. Each socket is impact-rated and designed to fit snugly on the driver shaft for secure operation and storage.

The line expansion also includes new Premium Grip Handles featuring ergonomic over-molded grips for enhanced comfort and control, and a washer-style quick-release mechanism for fast, secure bit changes. Premium Grip Handles are available in three sizes: Stubby, Standard and Bit-Storage Handle. The Built-In Bit Storage Handle (HPGB) stores 12 impact-rated bits including flathead, Phillips, Star and Robertson bits in multiple sizes.

Finally, the C-RHEX® line now includes a

variety pack of the impact-grade GoBlue! Hex Drivers in 1/4", 5/16" and 3/8" sizes. These self-adjusting, spring-loaded drivers automatically adjust to all types of fasteners of varying head heights, allowing for secure and worry-free fastener placement. Constructed with S2 hardened steel, GoBlue! Hex Drivers are built to withstand high torque and heavy use with power tools of any brand.

"Malco is excited to offer additional value to trade pros by expanding our popular C-RHEX line," said Rebecca Talbot, vice president of marketing at The Malco Group. "The new kits and socket sizes are great additions that will help pros work faster and smarter."

www.malcotools.com



SENCO SNS45XP Construction Stapler

KYOCERA SENCO Industrial Tools (SENCO), a global leader in pneumatic and cordless fastening solutions, has announced it will build an updated version of its SNS45XP 16-gauge construction stapler at its Cincinnati, Ohio, facility with global materials. While the SNS45XP name will be familiar to long-time SENCO users, the new stapler is designed for professionals that demand increased speed, power, and durability on the toughest jobsites and in plant manufacturing environments.

Building on the SNS45XP's legacy of toughness, the new version offers a range of features to enhance productivity and service life including:

- Drives up to 15 staples per second into the densest substrates including engineered lumber
- Consistent, precise depth control with a tool-free, adjustable depth-of-drive
- Top loading magazine with 160 staple capacity
- Quick clear latch to remove jams or mis-feeds without requiring another tool
- Ideal for sheathing, subflooring, decking, and pallet assembly

www.senco.com

AmeriLux Acquires MacCourt Products, Inc.

AmeriLux has announced the acquisition of MacCourt Products, Inc., a leader in the building materials industry known for durable outdoor solutions such as basement window well covers, mortar tubs, and preformed ponds.

MacCourt will join forces with Shape Products, an AmeriLux Family of Companies (AFOC) entity. Together, the organizations will combine their manufacturing expertise, product offerings, and customer service capabilities to deliver an even broader range of high-quality products to customers nationwide.

Kurt Voss, CEO of the AmeriLux Family of Companies, shared: “Through this acquisition, AmeriLux will maximize our ability to better serve customers in ways that support their success. The acquisition will also bring new job creation to our plant in Menomonie, Wisconsin, which remains a key focus of our organization. This is another step forward in building a sustainable enterprise.”



MFM Building Products Marks 65th Anniversary in 2026

MFM Building Products, a manufacturer of a full envelope of waterproofing and weather barrier products for the building industry, will be celebrating the company’s 65th Anniversary in 2026.

MFM Building Products was founded in 1961 in Coshocton, Ohio. Initially, the company manufactured products used for wrapping underground pipe to protect from water penetration and pipe contents becoming contaminated. Over the years, MFM expanded this technology to develop sealing and waterproofing products for use within the building envelope. In July 2017, MFM became a

100% employee-owned ESOP company that still holds true to its original core values.

Today, MFM manufactures a wide array of self-adhered weather barrier products that include low-slope roofing membranes, roofing underlayments, window and door flashing tapes, multi-purpose waterproofing membranes, specialized waterproofing tapes, and HVAC duct and pipe wrap.

MFM products are manufactured in the United States and sold through an extensive distributor network around the globe. The company’s products qualify for the Buy American Act (BAA) and Build America Buy American Act (BABAA).

Central States Promotes Eder Garcia to VP of Supply Chain

Central States, a manufacturer of metal building components and systems, has announced the promotion of Eder Garcia to Vice President of Supply Chain, effective immediately. In this expanded leadership role, Garcia will oversee both the Logistics and Procurement functions, driving strategic alignment across the company’s ever growing supply chain operations.

Garcia joined Central States on December 12, 2018, and has held

multiple leadership roles across logistics, manufacturing, and regional operations, most recently serving as Vice President of Operational Excellence. Throughout his tenure, he has consistently demonstrated the company’s core values and a strong commitment to advancing both business performance and organizational culture.







“I am honored to step into this new role and continue serving the incredible team at Central States,” said Garcia. “Over the past six years, I’ve seen firsthand how our employee-owner culture drives innovation and excellence. I look forward to building on that foundation as we strengthen our supply chain and deliver even greater value to our customers.”

Central States CEO Jim Sliker praised Garcia’s leadership and impact: “Eder is a proven leader who brings deep operational insight and a servant leadership mindset to everything he does. His promotion reflects our confidence in his ability to lead a unified supply chain strategy that supports our growth, enhances service, and empowers our employee-owners.”

Garcia’s promotion is part of Central States’ broader initiative to elevate internal talent and streamline operations as the company continues to expand its national footprint. **FBN**



Eder Garcia, Central States Vice President of Supply Chain

LAM-PLY-TRUSS

RIDING ARENAS • CATTLE ENCLOSURES • STORAGE • SHOPS

- Spans up to 72 ft.
- Bird nesting control
- Up to 12 ft. spacing depending on desired load
- No feed alley post obstruction
- Additional ceiling height for more usable space

starwoodrafters.com • 715-985-3117 • 888-525-5878

SBCA Component Craft

New National Symposium Will Help Post-Frame Building Designers

■ By SBCA Staff

In today's construction environment, building designers and component manufacturers often only communicate through RFIs. This limited cross-communication, at best, reduces opportunities to optimize structural systems, and at worst, leads to a general lack of understanding about how structural components, like trusses, perform in the field.

SBCA's new symposium, SBCA Component Craft, aims to shift that dynamic, and ultimately alleviate the need for submitting waves of RFIs. It is intended to bring designers, engineers, inspectors, and component manufacturers together in one place to explore how components are designed, fabricated, and installed, and to begin building the kind of shared understanding the building construction industry has long needed, leading to better quality plans. Increasing engagement from building designers will extend these benefits beyond component manufacturers, helping post-frame builders through improved plan quality and better coordination overall.

What is SBCA Component Craft?

SBCA Component Craft is a new regional education series designed by SBCA to bridge the gap between those who design, build, and regulate structural components and the manufacturers who produce them. Held in unique, community-focused venues such as brewery tasting rooms rather than traditional conference rooms, the format is intentionally crafted to spark organic conversations and begin building lasting business-to-business relationships. The goal is simple: provide building designers a clearer picture of the complexity and sophistication behind today's component design and manufacturing processes, and, in turn, give manufacturers and framers more

complete plans to work from.

SBCA Component Craft will blend technical education, hands-on demonstrations, and open dialogue to create a learning experience that helps attendees understand not just what components are, but why they are engineered the way they are, and the best practices for how they should be specified, installed, and inspected. The symposium will move throughout the country, with the first event in Austin, TX (see box inset).

Who is SBCA Component Craft For?

This symposium was built specifically for the people whose decisions most directly

shape a building's structural system:

- Architects
- Engineers
- Residential building designers
- Plan reviewers and code officials

These are the individuals who create, refine, and approve the plans that guide how structural components are used. SBCA Component Craft provides designers and regulators with a rare, behind-the-scenes view of how components are engineered and fabricated, how they perform in the field, and what information manufacturers need to build the most efficient and accurate structural solutions.

Attendees will be exposed to the level of precision required in modern component manufacturing and, in the process, gain the confidence to design and specify with structural components more effectively. They will learn why even small details, such as heel height, overhang dimensions, sequencing, and plan clarity, directly impact the success of a project.

SBCA Component Craft is also intended to attract building design innovators, the architects and engineers who want to more fully understand the construction tools, technologies, and systems available to them so they can push their designs further, deliver better plans, and reduce downstream errors.

Why Post-Frame Builders Benefit When Their Building Designers Attend

For post-frame builders, having the designers they work with attend SBCA Component Craft provides direct, measurable advantages. Post-frame construction incorporated increasingly more sophisticated and high-performing structures, yet many designers working in the post-frame market have limited exposure to how these components are engineered or how their decisions influence everything from cost,



SBCA Component Craft

What: A new regional symposium series connecting the people who design and regulate the use of structural components.

Who: Architects, engineers, code officials, and residential building designers.

Why: To build confidence, clarity, and a better understand of how structural components like long-span roof trusses are designed and perform.

Where: The Brewtorium Brewery & Kitchen, Austin, TX*

When: February 24–25, 2026

***Additional Locations Coming in 2026:** Boston, Nashville, Southwest U.S.

Learn more: sbccomponentcraft.com

cycle time, field installation, and long-term performance.

Post-frame projects can succeed or struggle based on the clarity of the building plans. When designers fully understand component capabilities, loading requirements, tolerances, connection details, and manufacturing constraints, the plans they create reduce ambiguity in the field. Component manufacturers rely on accurate plans; even slight uncertainties lead to RFIs, redesigns, jobsite delays, and/or costly field fixes. Again, SBCA Component Craft seeks to address these challenges by giving designers insight into what information manufacturers need and how design choices translate into manufacturing and field realities.

Many light-frame building designers still view components as a substitution for stick framing rather than an integrated framing solution. SBCA Component Craft will explore how components—especially roof trusses—can expand design flexibility, reduce material use, achieve longer clear spans, and improve structural consistency. When designers fully understand these capabilities, they can specify components earlier and more intentionally to unlock structural efficiencies that benefit builders and end-users alike.

It's also true that the component manufacturing industry is far more advanced than many building designers realize. SBCA Component Craft will expose attendees to the technology, software, precision, and engineering expertise that is required today to deliver high-performing components like long span trusses. When designers understand this sophistication, they will gain confidence in designing and specifying components and become better long-term partners for post-frame builders.

Finally, education alone is helpful—but memorable, conversation-driven education is what will truly move the needle towards greater collaboration and long-term project success. SBCA Component Craft's informal, community-style setting encourages the kinds of discussions that rarely happen between designers and manufacturers. These conversations help break

SBCA Component Craft At A Glance

SBCA Component Craft is a two-day event. Day one will consist of up to seven hours of accredited education covering the following topics:

- **Reading Between the Lines**

Understanding component drawings is essential to translating engineering intent into safe, efficient structures. This session walks through the anatomy of a Truss Design Drawing and related documents, decoding load cases, reactions, plate orientation, bracing, and specification notes.

- **Smarter by Design: Peak Component Performance**

Design decisions ripple through manufacturing, logistics, and installation. This session breaks down buildability, applicability, optimization, and utilization to provide clarity around the design and use of components.

- **Truss Talk: How They Work and Why They Matter**

Attendees will gain valuable insight into how trusses are engineered, fabricated, and applied in the field, and how collaboration among engineers, architects, and code officials ensures these critical systems perform safely and effectively.

- **Understanding TPI 1 and Design Roles**

This session breaks down Chapter 2 of TPI 1, outlining the specific roles of the Building Designer, Truss Designer, and Manufacturer. Attendees will learn how to interpret and apply these responsibilities in real projects.

- **Brace for Success: Component Installation and Safety Insights**

This session helps architects, engineers, and code officials understand the principles behind BCSI's guidance on handling, restraint, and bracing. Learn how

these practices impact structural performance.

- **Compliance with Components**

This practical code session will highlight recent interpretations and regional nuances – and show how design and manufacturing precision make compliance simpler and more predictable from start to finish.

- **Collaboration with Components from Design to Install**

This session explores how early coordination between building designers, engineers, component manufacturers, and installers eliminates costly miscommunication, improves build quality, and keeps schedules on track.

Day two will include a pre-tour education session, followed by a two-hour tour of a modern component manufacturing facility:

- **Inside the Shop: How Components Come to Life**

Before touring a component manufacturing facility, learn how design flows into cutting, assembly, and aspects such as QC. This session will cover material flow, machine capabilities, and basic logistics so you can connect what you see to the final field performance.

- **Guided Tour of a Local Component Manufacturing Facility**

See firsthand the systems and processes behind the concepts shared on day one with a 2-hour guided tour of a component manufacturing facility located near The Brewtorium Brewery & Kitchen. Transportation is provided and is highly recommended due to parking constraints.

FBN

down silos, build trust, and foster ongoing collaboration that directly benefits future post-frame projects.

Bottom Line

Post-frame builders can have even greater success when the building designers they rely on fully understand structural components and how to use them effectively. SBCA Component Craft is

built to deliver that understanding through practical education, honest dialogue, and firsthand exposure to the component design and manufacturing process.

By encouraging the building designers, engineers, and code officials they work with to attend, post-frame builders are taking a significant and positive step towards better building plans and better buildings.

FBN

You Can Help Raise the Bar

Why You Should Submit Your Next Post-Frame Project

■ By Karen Knapstein

You build more than structures — you build solutions. Everyday, contractors across the country deliver buildings that solve real problems: livestock shelter, storage, workspaces, homes, and more. But too often, these successes go unseen. The Frame Building News Projects of the Month exists to change that, by spotlighting outstanding post-frame buildings and showing what this versatile construction method can really do.

• **Reach a national audience — for free**

Submitting a project costs nothing. If selected, your company gets published in the longest-running, most widely distributed magazine dedicated solely to post-frame construction. That means nationwide exposure — to builders, suppliers, and potential clients who look to FBN for inspiration and standards.

• **Show what real post-frame looks like — and help raise the bar**

By contributing your project, you're not just showing off your craftsmanship — you're helping redefine expectations. Every featured building becomes a benchmark of what a quality, long-lasting post-frame structure should be. That visibility builds your reputation as a leader in the industry.

• **Help grow the post-frame industry**

Post-frame construction is more than barns and sheds — it's increasingly used for light commercial work, residences, storage, and more. As post-frame gains acceptance across applications,

showcasing real, diverse projects helps more builders and clients see what's possible. Your project could inspire someone else's next build — and help grow demand across the industry.

- It's easy — submit with minimal effort

Getting published is simple. Fill out the online form with your company and project details, list components used, upload a few clear, high-resolution images — that's it. (Or you can send them in an email to karen@shieldwallmedia.com.) If chosen, you'll review the layout before it is published.

What You Gain by Sharing Your Work

Free marketing and credibility — Being featured in Frame Building News gives you industry-wide recognition, without spending a dime on advertising.

A "seal of quality" to show potential clients — Use the "As Seen in Frame Building News" badge on your proposals, website, and social media to show you meet high professional standards.

Contribution to industry growth and standards — By publicly sharing well-executed projects, you help educate peers and clients on post-frame's possibilities, pushing the industry forward.

Why Now Is the Right Time

The post-frame industry is growing. According to data from Shield Wall Media, demand for post-frame in light commercial, agricultural, and residential sectors has never been stronger.



By contributing projects now, you get in while the spotlight is on — and you help shape what post-frame construction becomes. Whether it's barns, workshops, commercial buildings, homes, or specialty structures — every well-built post-frame project helps tell the story and show what's possible.

Ready to Get Featured?

Submitting is easy. Visit the FBN submission page (<https://framebuildingnews.com/get-your-project-featured-free/> or scan the QR code above), fill out the form with your company details, project info, components used, and upload some good photos. If your project is selected, you'll get a confirmation and review opportunity before publication. Feel free to contact me directly if you have questions.

If you're proud of the buildings you build — and want to build your reputation while helping grow the industry — there's no reason to wait. Share your next post-frame success with Frame Building News readers. **FBN**

Survey Data: What do you need to know?

One of the nice things about a small company like ours is it provides a degree of flexibility. We're just wrapping up our primary CSI-Survey, which we execute each fall. We publish the findings in our Annual & Market Report. When special circumstances arise, we do additional market sentiment polls. We did one recently on glulam and nail-lam column usage. In past years we would also do a mid-year survey.

In addition to the column usage survey, we have done surveys on everything from preferred metal roofing colors to what size footer plates builders use for post-frame building projects.

When we have a gap in our schedule, I would like to fill it with a great survey idea. What should it be? What information would help you?

If you have an idea of a simple topic (it should be five questions or less), share it and maybe we will do your survey!

We can write the questions, we just need you to tell us what you want to know.

Thanks for your help.
 Send suggestions to gary@shieldwallmedia.com. **FBN**

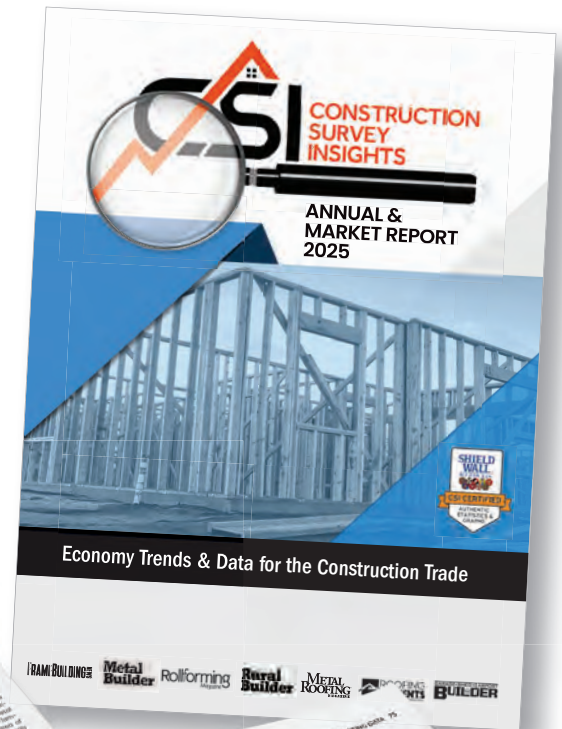



INFINITY SHIELD®



ENERGY EFFICIENT:

- Reflects radiant heat reducing heat gain and loss.
- Reduces heightened fluctuations in attic temperatures.
- Maximizes comfort.



COST REDUCING:

- Reduces energy costs year-round.



LABOR/TIME SAVING:

- Lightweight and easy to handle. Fast and easy installation. No seams on 6' and 8' rolls to maximize uniformity. Adhesive option available.



DURABLE:

- Puncture and tear resistant.



MADE IN THE U.S.A.:

- MWI is proud to produce Infinity Shield in Spencer, Iowa, U.S.A.



SEE YOU IN OKLAHOMA CITY!



mwicomponents.com

800-360-6467

Spencer, Iowa

